

The Anarchist Library
Anti-Copyright



Phil A. Neel and Nick Chavez
Forest and Factory
The Science and the Fiction of Communism
December 2023

Retrieved on January 9th, 2023 from
<endnotes.org.uk/posts/forest-and-factory>

See also the zine form of this text from *Haters Magazine*:
<haters.noblogs.org/files/2024/01/Forest-and-Factory.pdf> &
<haters.noblogs.org/files/2024/01/Forest-and-Factory-imposed.pdf>

theanarchistlibrary.org

Forest and Factory

The Science and the Fiction of Communism

Phil A. Neel and Nick Chavez

FOREST AND FACTORY

The Science and the Fiction of
Communism

Phil A. Neel and Nick Chavez



December 2023

it from achieving the global scope necessary to its full realization. The question is therefore less about how communism itself will work and more about how we can remain communists while the conditions necessary for full communism remain out of reach. At the same time, we have tried to show that there are, essentially, no hard and fast *technical* constraints preventing our present world from operating in a communist fashion. The “productive forces” do not need to be developed until we have achieved “full automation” for a communist social order to be feasible. Communist construction could very well begin today, if the collective political subjectivity existed to begin such a project. Sadly, it does not, and building up this subjective force—i.e., building communist power—is its own long, difficult process.⁴⁴ As Mau argues, however, thought itself is an integral part of this process. Perhaps this inquiry might contribute, in some small way, to that grander project, such that someday fragments of our present world might be wrested from the machine systems of capital and built into something new through long struggle and loving devotion to the utopian task tens of thousands of years in the making, and ending, at last, the pre-history of the human species.

⁴⁴ Though not our focus here, we can summarize this as the process of composing a collective revolutionary subject—not so much a singular “party organization” as a culture or ecosystem of partisanship and organization that exceeds any one formal institution—capable of acting with a certain degree of distributed intent within, through, and beyond myriad struggles over the terms of subsistence within capitalist society such that these struggles are pushed beyond their limits in the general direction of decommodification. In other words: not founding some ideal party to lead the struggle but building out the real party bequeathed to us by the chaos and contingency of history.

of a better world, then, but something cultivated first from rage at what the world is not. We do not glimpse it. We feel it in moments of fever—of cities burning, of order breaking down, of loved ones dying slow and unremarkable deaths, of another hard day of work in lives seething with toil as endless as unnecessary—not seen but instead sensed in the way we sense the pressure change before a storm, felt in the skin and in the dancing of that shard of calcium carbonate deep in the inner ear. Rather than the eye, the otolith. Because a better world is not built backwards from the future but from where we stand now, at the peak of the mountain of bones that constitutes the pre-history of the human species. This world—which is “ours” only in the sense that we live in it and, in so doing, create it—is alien but not incomprehensible. It can at least be felt, and anything that we can feel we can grapple with. The drywall, lacking luster, was built from materials, machines, and human labor that can very well be used to tear through it. Maybe that window of depthless light offers some sort of blueprint, tracing out the frame of demolition—as they say, every window is a door for the brave and the reckless. There must, then, be a logical thread that connects this world that we wrestle against to the dim prospect of communism, however difficult to articulate.

The science fiction of a communist society is inspiring not when it is most outlandish and fantastical, then, but when worlds fundamentally different from our own are shown to be nonetheless constructable from the mountain of bone bequeathed to us. Thus, the real emphasis of this fiction is less about the world that we have attempted to depict, in all its ambiguity, and more about the concrete moments that *precede* communism proper. Attentive readers will have already noticed that we have not so much provided a picture of communism itself as posed a series of questions about the sequence, character, duration, and constraints of the process of what we have referred to as “communist construction.” The real problem is not simply that communism cannot be a local affair but, in the near term at least, will have geographic limits that prevent

Contents

Tangibilities	5
The Fundamental Principles of Communism	12
Localities	20
Association and Deliberation	27
The Ecosystem of Industry	36
Planned and Planetary Limits	40
The Motor of History	51
Construction and Conclusion	65

seasons and the oscillations of the great motor of history. Possibly an annual hajj to some hall of industry where children, on their inaugural journey far beyond the home, may for the first time witness how the wheels of the world turn; where the young might travel boastful, brimming with life and seeking adventure—the days filled with playful service, the nights full of passion and novelty—they leave transformed; or where the old might return at last, weary with nostalgia and hungry to see the place where they first witnessed the world turning and bodies spiral through the seasons of the flesh.

Construction and Conclusion

The verdant jungle projected onto the drywall is nothing more than a vague canvas onto which equally vague desires are projected, off-white. Lush foliage and the cacophony of animal life, from insectile to avian, resonates in a primordial part of the brain, some sort of chordate neurological adaptation accreted over evolutionary timescales. The part of us that hungers and fears finds its home in this chaos of green. But the subconscious appeal to the specifically sapien part of our mind is less about the jungle itself and more about the fact that it is some place that is *not here*. It is literally distant, but also qualitatively so: someplace pristine, where the warm rains wash away the sins and the scars of our own—decidedly less verdant and more vacuous—lives. Someplace that cultivates, rather than simply casting capital ever-forward on its mindless circuit. Touching a hand to the image on the wall is equally enlightening. Lessons are learned through the body, and the instruction given by drywall to skin is twofold: the jungle paradise is without substance, but the wall itself is very real.

To reach out and touch utopia requires you touch the world in front of you first. The future can only ever be the unfolding of the present in which you live. Communism is not the loving daydream

of these automation associations may consider all of this beneath them. Perhaps they carry out their tasks in an eremitic fashion, conducting their research in scientific monasteries wrapped in mist and hidden deep in the world's least accessible locales, only deigning to visit manufacturing associations that pose the grandest of challenges. They argue that their duty is a momentous one—sacred, even—and that it should not be treated as a mere game.

On the other hand, the solution to the problem of labor-intensive assembly may also be social, rather than technical in character. Similar to day-to-day tasks such as cleaning, cooking, maintenance, and measurement, we would imagine that remaining necessities in simple assembly might take on entirely new cultural forms. Maybe ceremonies arise around certain core components. Again: we can think of this industrial system as something like a food forest, tended like the land. And these agroecological practices have always involved both day-to-day cultivation and large-scale seasonal stewardship rendered culturally legible through ceremony. There is no reason to assume that mass manufacturing could not be administered, at last in part, via similar means. This is especially true when we remember that the divide between “individual self-interest” and the “public good” that seems so natural to us is, in the end, an artifact of mercantile logic. Perhaps, then, certain core goods become subject to new social rituals. For our motors, these would obviously be cyclical in nature: some sort of pilgrimage to honor the turning of the

professional dominatrices. The point is, ultimately, that the communards of the future only know of the barbarism of proletarian dispossession through vestigial echoes left in games and in the sexual subconscious. The most direct contact they would have with the forms of social domination we ourselves are intimately familiar with would be via history lessons and dramatic period pieces where capitalist scions, portrayed as fancifully as fairy-tale medieval nobility, jockey for favor from the mystical god known as “Stock Market” using a magical ritual called the “layoff” wherein workers are sacrificed at the altar of “Quarterly Report” at the hands of some sort of strange and unpopular priest called “Human Resource Manager.”

“Although the utopian does see the effects of present-day society (in fact Marx praises respectfully some of the masters of utopian thought), his error lies in deducing the shape of future society not from a concatenation of real processes that link the course of the past to that of the future, not from natural and social reality, but from his own head, from human reason. The utopian believes that the goal of society's course must be contained in the victory of certain general principles that are innate in the human spirit.”

— Amadeo Bordiga¹

Tangibilities

It doesn't matter where you move. You walk through echoes of the same room plastered the same off-white. There are the same coffee shops of wood and chrome. Your workplaces are warehouses, offices, construction sites. It doesn't matter. All hollow boxes filled with shuffling people bleeding hope slow and dark as organ blood. The kind of trail left by hunted animals. Like any fleeing thing, we seek refuge where we can. You come home to the only basement or closet you can afford in this bright, damned city always built for someone richer—you are caked in that soft glitter of fiberglass from the worksite or wreathed in the soft ache of a day hunched over the desk, over the counter, over the beds of hospice patients wracked with the slow agony of a life ripping out of them like deep roots from loosened soil—and you saw something on one of the apps that seemed like a salve so you try it. You pull out some cheap projector and cast onto that off-white wall a video looped on repeat, the image of a window and beyond it rain pattering softly into the canopy

¹ In: *The Science and Passion of Communism: Selected Writings of Amadeo Bordiga (1912–1965)*, Pietro Basso (Ed.), Giacomo Donis and Patrick Camiller (Trans.), Chicago: Haymarket, 2020, p.453

of a verdant forest, the trees quivering with the terrible green flood of real life, the sound quivering out of your small speakers like real rain, and the sad solace quivering across your skin like a real feeling as you press your hand to the scene and feel nothing beneath but spackle on drywall, off-white.

Today's utopias are much the same. They are buried in the blue glow of screens that look like windows but are something less. We have seen breathtaking cathedrals built in Minecraft. We have wandered in melancholy worship through the "liminal spaces" of urbex vloggers and backrooms forums. We have felt the sublime warmth of Miyazaki and the solarpunk imageboard. Sometimes, we can even pretend that distant locales offer something more substantial: the Lacandon Jungle, Rojava, Cuba, even the Pyongyang of the propaganda poster (at that perfect aesthetic midpoint between Stalin and Wes Anderson). But for most of us these "real places" remain images, unmuddied by the murk and blood of material struggle. Like the soft blue glow, they are an intimate coldness. Cosplay, rather than politics.

Closer to home, desperation even might push us to "envision real utopias" in any marginal glimmer of communality: the noble Wikipedia editor, the worker cooperative competing on the global market, the sharing of food at the protest camp, the persistence of the public library despite the endless assault of privatization, the urban garden tended by the six-figure NGO executive, the sharing of cigarettes near the dumpsters behind the kitchen, or simply the commonplace care work that knits us to family and friends. To imagine that such things are somehow the germ of communism would be a joke if it was not so tragic. Like someone who believes that the window projected onto the wall is the real thing. The bleak reality is that none of us have ever seen even the dimmest glimmer of a communist world—at most we have witnessed a few of those weightless moments when many people realize at once that our world can, in fact, be broken. Ultimately, these are nothing but glowing images best seen from a distance. Reach out to touch them

may take many forms. Some will likely be styled on a sporting model, in which different associations of automation enthusiasts consult with manufacturing associations and engage in friendly competition to see who can minimize both the amount and discomfort of manual labor in the given product line. Maybe one association retools a small fleet of robotic arms that they had designed in an earlier contest, hoping that the machines will remain versatile enough for assembly of these smaller components. At the same time, we might imagine that a new process is being trialed by another automation group where prototype subassemblies (of a new type more suitable to this novel process) are all dumped in a simple padded rotating bin where, after several hours, the random chance of collision inside the bin has caused the motors to self-assemble.⁴² But the process needs refinement and may not be ready any time soon.

Overall, these competitions would be arbitrated by the manufacturing association itself, which chooses a victor based on its own appraised needs. The only reward from this sport-like competition would be prestige and a sense of satisfaction. Given that it will likely create an incredibly fierce environment rife with drama, bruised egos, and fluctuations in perceived social status, it can also be imagined that conflict resolution associations might be involved to ensure that the game does not get out of hand—one association sabotaging the work of another, for example.⁴³ But the most skilled

⁴² This technology is currently feasible, but still being developed by MIT scientists.

⁴³ Failure also entails no material loss. In other words, unlike the capitalist labor market, this sort of sporting competition does not threaten its participants with loss of access to the means of subsistence or access to the pleasures of life in any way. It is just the loss of what is ultimately an elaborate game. Of course, specialist associations would be on guard against games such as this taking on too serious a character and inadvertently reinventing *de facto* forms of domination through their incentive systems. The same would go for voluntary participation in elaborate lived simulations—perhaps there are people who take a certain masochistic pleasure in erotic live-action-roleplay as "workers" paid "wages" by

electronics such as these motors and do not require comparatively rare materials. Because even simple magnets can be complicated to manufacture, a couple of big facilities produce them in larger quantities using fixed production methods according to specific geometries, material compositions, and field properties. There are specialists who will make custom magnets for critical scientific or infrastructural purposes, but this is rare. The vast majority of magnets, like the kind used in these motors, come from mass manufacturing lines.

At the motor factory, the magazines of special machines are loaded with magnets for rapid insertion into the stator. Because the stators (here they are the same component as the outer casing) are variable in shape, size, and number of spots for magnets, the magnet loader must be configurable. Magazines are added or subtracted so that there is one per magnet slot on the stator, and they are positioned appropriately. Once the machine is configured, an operator (or even a robotic arm using machine vision) simply presses each stator into a recess where it is automatically aligned as the magnets are pressed up into the pockets. The stator was designed to hold the magnets with a simple press-fit along the direction parallel to the stator axis, and the geometry of the pockets prevents them from being dislocated radially. Now that all subassemblies are made, the final assembly can proceed. Under capitalism, this would likely be done by hand by workers trained in the use of special tools but requiring no further specialist knowledge or training. The labor-intensive nature of assembly means that capitalist firms planning production to meet profit constraints will be encouraged to find people whose labor has been cheapened by various means, the most important of which is the imperial hierarchy of labor arbitrage structuring global supply chains. Under communism, it is this assembly labor that poses the biggest hurdle. We can expect both technical and social solutions.

On the one hand, there will almost certainly be dedicated associations attempting to automate once-manual processes. These

and there is no depth. Just work, survival, desperation. Just the dry-wall, off-white.

In the course of these same years where every summer seems to be the hottest ever, where the storms dance deadly across our cities like drunken gods, and where, despite everything getting worse, every insurrection has been decisively strangled in the name of that same old status quo—it is hardly a coincidence that there has also been a proliferation of new “political” attempts to sketch out detailed utopias, attempting to answer the question of “what does communism look like?” or “how would a socialist society operate?” The proliferation and popularity of these utopian fantasies at least demonstrates that many hunger for that next world imprisoned in this one, if only they could free it. And, in this sense, the production and refinement of these fictions at first seems to serve some sort of political purpose. This is often the justification offered by their authors, at least. Even if ideas in and of themselves cannot generate historical change, we might presume that political imaginaries can help us to “orient” activity in some fashion.² If we take this claim as given, then the diversity of these utopias would thereby act as expression for concrete political differences. In other words, these fictions would don the garb of “strategy,” and each micro-genre would then serve as its own “orientation” around which a more practical politics might cohere.

But the reality is that the suppression of open class conflict throughout society—combined with the generally low level of hands-on knowledge of production induced by deindustrialization—has tended to impoverish the practical or functional aspect of “political thought” in general and of discourse and imagination in particular. The result is that most signals of apparent political or strategic difference are in fact little more than an index of the tastes, aesthetics, and desires prioritized by differ-

² See: Jacob Blumenfeld, “Lifting the Ban”, *The Brooklyn Rail*, July-August 2021.

ent authors and audiences occupying their different subcultural niches in the cavernous marketplace. Today's utopias therefore operate over an enormous breadth: ranging from hyperbolic tales of the permanently-embarrassed futurist ("fully automated luxury communism"), to planning schema that would channel resources and populations at the behest of aspiring technocrats ("half-earth socialism," "degrowth communism"), to folksier fairytales of city-scale "communes" popping up like little mushrooms of self-organization in the interstices of society or under the umbrella of insurrection. Some of the more fanciful visions will contain the occasional moment of lucidity, while others are wholly detached from reality.

Despite their apparent divergences, all tend to operate according to a shared logic that is utopian not because it is imaginative but because it lacks any real substance or depth. Though their forms seem multifarious, such stories cast a single shadow onto that same flat surface, off-white. In other words, these utopias are unified less by the positive content of the worlds that they envision than by the fact that they all share the same glaring absences etched onto the same fictive flatness: first and foremost, we find the absence of "politics" itself, in the sense of some strategic sequence of struggle stretched between the immediate world and the envisioned utopia—after all, "utopia" is a non-place not because it cannot be envisioned but because no path can be stretched from here to there; and second, we find negative imprints left by questions that all such utopias refuse to ask. How, exactly, will production of anything other than simple handicrafts be conducted at both the social and technical level (without deferring to the magical fix of "direct democracy" and "full automation"). Or: how might such a system arise not despite but through the inherently uneven and disorderly revolutionary process itself? This is a selective refusal of rigor that, at best, arises when authors use familiar or commonsense notions to paper over their failures of imagination and, at worst, serves to disguise the reactionary impulse that haunts the utopian imagina-

pervising and tending the machines is, often, quite meditative. It is just as likely that these individuals perceive a certain beauty in it, or even religious awe—the melding of mathematics and materials in mechanical harmony, arcane labyrinths etched with living light—and shepherd these machines much as one might tend to a garden or a temple.

Permanent magnets can be made from a variety of different ferromagnetic and ferrimagnetic materials, some significantly rarer or more difficult to refine than others.⁴⁰ These particular motors cannot be made without magnets but, in most cases, it would be possible to prioritize the use of more common materials. Ferrite, a ceramic containing abundant metals, can be easily made into permanent magnets.⁴¹ These magnets are not as strong as, say, neodymium magnets, but they are perfectly adequate for many

⁴⁰ Overall, communist society would see greatly diminished manufacturing of permanent magnets compared to production under capitalism. This is partially because communism will entail the production of a reduced volume of artifacts overall. But the socio-technical process of mining and metals refining would also be transformed at a fundamental level. In general, we can assume that associations specializing in geology, mining, and metallurgy would prioritize high-energy forms of recycling and synthesis from low-concentration sources even though these are less "efficient" in cost terms today. Many other "inefficiencies" would also be apparent, including rigorous and redundant containment infrastructure for waste products, ameliorative activities in the surrounding area, and intensive cultural campaigns serving to increase local knowledge of the process, draw more members into the relevant associations, and honor the contributions of the land and ecosystems impacted. In the case of materials like rare-earths, planned limits would be even more stringent—not due to their "rarity" (they are not actually that scarce) but because of the more extreme environmental and health impacts of their mining and processing, whether from reserves on land or from deep-sea deposits. Since rare-earths are used for a variety of important goods aside from magnets, we can imagine that using them in simple motors such as these would be low on the list of priority.

⁴¹ Ferrite is produced by mixing and firing iron oxide (i.e., rust) with another metallic element (usually strontium, barium, manganese, nickel or zinc), and would thus be sensitive to production decisions by associations responsible for mining and processing iron ore or any of these other metals.

ture body, although it is more likely that the design will call for an outer casing made of metal. This can be done with the metal sintering 3D printers, although sometimes this association will partner with a metal casting³⁹ association for higher volume production runs. The brush and commutator must be made of an electrically conductive material capable of withstanding repeated friction without wearing down, and as such these are almost guaranteed to be made of metal and manufactured as such.

The copper wire, itself a ubiquitous artifact extruded in massive quantities in just a small number of highly automated facilities around the globe, is wound around the armature body using a couple of robotic machines tooled specifically for this purpose. For both the powder bed 3D printing of the armature itself and the winding of the wires around the armature, operators are spared most of the manual labor but must still perform some repetitive actions in addition to supervising the machines. These individuals are likely to be the same people who configure and maintain these machines, and thus know them intimately. Absent a profit motive, there is little need for a rigid technical division of labor between what, under capitalism, is called engineering, technician, and operator labor. These individuals have every incentive (and the necessary technical expertise) to reduce the absolute quantity of tedious manual labor they must perform by simplifying the assembly process or introducing automation measures. If there is uncharacteristically high demand for motors and the labor required to supervise the winding process takes more than a few hours a week, additional people may come in for a second shift that counts towards time that would have otherwise been spent performing tedious but important labor like cleaning the streets or unclogging faulty sewage pumps. It is possible that any given operator finds such work a tedious necessity of a similar sort. But the act of su-

³⁹ Casting is a process in which molten material is poured into a mold, which is well suited for producing large quantities of identical components.

tion. In this sense, such utopias compose what philosopher Emil Cioran referred to as an “idolatry of tomorrow,” in which the very attempt to dream up the future in all its detail “blocks our ability to have a future at all.”³

One might be tempted here to then equate the “utopian” with any fictive or imaginative approach to politics and then contrast it to a “scientific” alternative understood to be concerned purely with matters of practice and critique. But this does not really make sense. The imaginative, aesthetic, literary, inventive, and intuitive dimensions of politics—however intellectually shallow or fashionably pretentious—ultimately take on an outsize influence in the construction of popular power. It does not matter how correct or critical your analysis is if no one is attracted to it in the first place. And this attraction is not a logical thing, nor is it a process of careful argument or enlightened discourse and debate. Thought occurs first through affect and analogy—through the crass calculus of the vibe rather than the immaculate mathematics of the mind. The problem with the utopia, then, is *not* that it is science fiction. Its fictive power is precisely why utopia is able to wield such a disproportionate force in the political imagination and therefore why the artful production of attractive aesthetics and imaginative worlds will be essential to the practical construction of any political project. The problem is instead that most utopias are not actually *science* fiction—or, at least, not “hard” science fiction, distinguishable from fantasy for its efforts to take the physical world seriously.

In other words, what makes these fictive endeavors “utopian” in the bad sense is that they are not treated as rigorous experiments of imagination that must align, at least in certain fundamental features, with the material limits of our reality, and must accord, in some feasible way, with realistic presumptions about the path of political conflict that would stretch from here to there. Nor are

³ The initial quote is from Cioran’s *The Fall into Time* (Quadrangle Press, 1970, p.47), and the subsequent description is from Blumenfeld 2021.

these thought experiments committed to anything like a scientific methodology—dissolving “common sense” appearances with the corrosive force of critical inquiry. They are instead largely uncritical, taking the immediate (and inherently alienated) appearance of the world at face value. Rather than science fiction, then, they are something more like magical realism, mirroring reality in the exaggerated form of a fable. These utopias therefore act as what Lenin called a “wish that can never come true,” or, more pointedly, “a wish that is not based on social forces and is not supported by the growth and development of political, class forces.” The problem is not that they are imaginative or fanciful—that they express a wish for the future—but that there is nothing behind them that could make the wish come true. Their aesthetics do not link to any substantial, scientific critique of how capitalist society actually operates and their feats of imagination do not attempt to think through the very real problems of—social, technical, ecological—reconfiguration that will plague any attempt to break this world and build another. There is no thundering green forest beyond the window, only the same old drywall, off-white.

What, then, would a truly *scientific* alternative look like? We offer a practical example below, constructed according to the basic negative principle underlying scientific inquiry more generally: that any such account must foreground both the unknown and the unknowable. It is simply disingenuous to pretend that a communist world could easily be envisioned by individuals whose entire experiential context is that of capitalist society. Even if we might be able to sketch out some of the technical or social preconditions needed for such a world to emerge, this world would be fundamentally alien to us. Many utopias prove cheap not just for their lack of complexity or depth, but because they pretend that the people composing a future society will all be basically the same sort as those that compose the current one, carrying with them the same predilections, passions, and proficiencies. In other words, we find a

high performance biodegradable plastic formed from genetically engineered fungal colonies that can be turned to powder and used in this printer. This association (known for its particularly zealous members, who have a somewhat threatening air about them) has been aggressively promoting their new material, which promises to ease the present tradeoff between using arable land for biomass and keeping fossil fuel infrastructure running. Members of manufacturing associations often arrive at their workspaces—no longer located in “factories” or even “workshops” but in mixed spaces that have names entirely unfamiliar to us or playfully borrowed from the long history of utopian imagination: “ateliers,” “phalanstères,” “arcologies”—to find members of the mushroom mafia milling about in the shadows, wearing their distinctive trench coats and carrying their signature suitcases full of mycological samples and copies of philosophical works by their patron saint, a strange pre-revolutionary philosopher from the far Western tip of Eurasia. Sometimes members of production teams are even accosted in dark alleyways by the mafiosi, who ask why their association has not yet embraced the “Rhizomatic Revolution” and invite them to something called the “Deleuze Study Group.”³⁸

Many motor producers, out of some mixture of interest and intimidation, have agreed to roll out the mycological powders. For weaker motors these plastics (both nylon and fungal) work perfectly fine. For stronger or faster ones that require more heat dissipation the association also has similar printers onsite that sinter together metal powders into solid bodies, though the process is messier and more complicated. Since metal is more thermally conductive than plastic, the rotors of larger motors can be designed with a fan attached to provide active air cooling. The outer case of the motor can be manufactured with the same methods as the arma-

³⁸ We, on the other hand, would suggest that those interested in learning more about fungal systems are better off reading *Entangled Life* by Merlin Sheldrake, a biologist whose use of the word “rhizome” is not exhausting and tedious.

the armatures.³⁶ While the number of parts that can be output per hour is lower than with an injection molder, the amount of wasted material is much lower, as the unused powder can be fed back into the machine. Another advantage is that no tooling changes are needed for the printer if the part design changes. In fact, because of the large print volume, many different components of different designs can be printed simultaneously based on fluctuating demand with very little setup time. We can presume that, while the demand across the region for any given motor design would be higher than most industrial goods, few designs would require more than a couple hundred to be manufactured per week—the exceptions to this would be spikes due to the production of particularly large batches of some given downstream machine, requiring more direct coordination between the relevant associations.

When this type of additive manufacturing was inherited from the capitalist era, fabricators were limited to a perfectly usable, albeit difficult to recycle, type of nylon powder. The nylon resins used to produce nylon powder are today manufactured from certain side products of fossil fuel refining. We can maybe presume that some of the necessary feedstocks for nylon production have successfully shifted to renewable sources.³⁷ Perhaps an R&D association specializing in mycological materials (we can call them the “mushroom mafia”) has recently developed a new type of

³⁶ Powder Bed Fusion is an additive manufacturing technique in which thin layers of metal or plastic powder are sequentially melted and fused by lasers or an electron beam to build up a 3D component.

³⁷ For example, deriving acrylonitrile and butadiene (used to produce adiponitrile, which is used to produce hexamethylenediamine, one of the main ingredients needed to produce nylon) from biomass. This raises a conundrum, however, since the alternatives to many fundamental feedstocks within the chemical industry currently derived from fossil fuels rely on biomass inputs, leading to greater pressure on land use. Some might argue that continuing to balance this biomass consumption with hydrocarbon production (necessarily offset by some sort of carbon capture or sequestration technology) makes more sense than attempting to rely entirely on cropland for the production of alternative plastics.

colloquial communism, inhabited by people who are just like you or me—this new world the same as our present one, only better.

Against this, we would instead emphasize that a communist revolution is, fundamentally, an anthropological revolution. This means that it is genuinely difficult to understand what a better world would look like at the quotidian level, because such a world would also reshape those who inhabit it. The identifiable material and social prerequisites of this world (such as an end to scarcity in all essentials, ecological rehabilitation, and non-domination) would enable the blooming of new cultures and lifeways that are difficult or impossible for us to fully imagine. This difficulty is not due to the complexity or advanced nature of such a society. After all, we run into the same basic problem when trying to grasp what life was like in ancient social orders that were, at least in the technical sense, much simpler than our own. Whether looking forward or backward, our anthropological lifeworld imposes ideological limits on the imagination. We are broken creatures, our minds bound by the very social constraints that we seek to eliminate. And, while the anthropologist can at least go and observe the unfamiliar lifeways of other cultures and the archeologist can examine the remains of their material existence, the communist is faced with the more difficult dilemma posed by an “other” that is not just culturally distant but also decisively locked beyond our sight in the forward-flow of time, with not even the faintest of archeological fragments from which we might reconstruct the whole.

Below, we therefore offer a practical fiction rooted in a negative critique. Throughout, we will counterpose our account to what we think are common errors that plague the political imaginary while emphasizing the inherent unknowability and dynamic cultural efflorescence of a communist world. While the contrast between practical fiction and negative critique may seem paradoxical—an anti-utopian utopia—such a procedure is the nature of scientific inquiry. As in any scientific inquiry, the models that we pose

here are ultimately makeshift. But, without any ability to directly observe or experiment, a certain degree of fictive rigor is essential in their construction. Imagination must be subject to at least a minimum level of real constraints. Among these are the “social forces” and “political, class forces” that have been produced by the course of history, which Lenin emphasizes. In addition, we stress here the equally prominent role of “productive forces” as concrete sites of social power, irreducible to their technical characteristics. In fact, we would argue that the failure of nearly every utopian vision on offer today manifests most strongly in their treatment of the question of production, which is either ignored entirely, presumed to be a purely technical-ecological matter best left to the experts, or viewed as so thoroughly subordinated to capitalist logics that prevailing agricultural and industrial practices must be uniformly and fundamentally replaced—with what, exactly, it is rarely clear, though gestures are often made in the direction of local autarky. Questions of locality and the precise process of production will therefore serve as lenses bringing focus to our own anti-utopian utopia or, more simply, our contribution to the science fiction of communism.

The Fundamental Principles of Communism

Throughout this piece, we will orient our own narrative as a counterpoint to one recent utopian vision offered by communist philosopher Søren Mau in a short article written for the Verso blog, which we take to be broadly representative of the genre. Even while we emphasize the shortcomings of this vision, however, both our critique and our alternative to Mau’s account start from the same fundamental understanding of how capitalist society operates and, by association, what would be minimally necessary to overturn such an order. This understanding is laid

ity of certain materials, not to mention their characteristics (wire diameters, corrosion resistance of different aluminum alloys, geometries and field properties of permanent magnets) play a decisive role in constraining the practical design avenues that can be chosen. These parameter spaces are largely determined by aspects of our universe deeper and more rudimentary than the particular productive arrangements of any given human society. But these parameter spaces *only exist* within human society, and thus become a sort of prism through which social forms congeal into a chosen design path. Under capitalism, these parameters are therefore conditioned by monetary concerns. Not only does every manufacturer want to fabricate goods as cheaply as possible while still performing to specification, but the entire industrial (i.e., social) context—in the form of profit-driven supply chains, with all their real-world nuances—narrows the decision-making space from a matrix of infinite dimensions down to just a couple of options per parameter. Under communism, this infinite parameter space is also narrowed down to a similarly limited set of options. But, in this case, these parameters are not appraised through the matrix of cost but through deliberation attuned to social desires—and these desires will see substantial variation according to context. The exact options that emerge could be wildly different than those that currently exist, while still yielding motors that are perfectly adequate for the needs of those who desire them.

The armature’s body—a sort of cylinder with spoked arms running along its length, around which the coil is wound—can be fabricated in a number of different ways from a variety of material options. Let’s assume that the facility where this motor is manufactured is also used to fabricate not only other types of motors, but other electromechanical hardware. As such, the association has powder bed 3D printers capable of fabricating parts with almost any sort of geometry that fits within the build envelope, including

centralized. This information would be freely usable, modifiable, and rated by all. Picture a cross between Yelp and GitHub for engineering documents: design files, machine run programs, specifications, firmware code, instructions (assembly, validation, operation, maintenance, etc.), and other relevant documents are freely distributed and modified by anybody who wants to do so. The fully public nature of this platform enables significant access, traceability, modularity, and discussion for documents that today would be considered private intellectual property. Meanwhile, lists of depots, producers, and regular users would be readily available in any given area. Though composed of content contributed by producers, distributors, scientists, hobbyists, and archivists, such a platform would be an association unto itself, run by special curators, editors, designers, and software specialists.

For producers searching through these files, the chosen design and fabrication method would ultimately be contingent upon the specifics of the use-case and the technical methods accessible to the fabricators. In an abstract sense, the technical parameter space in which a motor designer must make design decisions would therefore not be that different between a capitalist and communist society. Wrapping extra wire around the armature increases the torque in proportion to the strength of the field but also generates more heat, and obviously requires more wire. Different materials and geometries may be more advantageous for heat dissipation but may be more difficult to fabricate or may take up more physical space. Certain geometries are easier to achieve with one fabrication method, and other geometries are easier to fabricate with a different fabrication method. This sort of knowledge would be cultivated at the practical level within the producers' associations, distributed at the abstract level throughout society via educational institutions, and gathered into a widely accessible form via these central information repositories.

Access to the machinery required for different forms of fabrication is both a technical and a geographic question. The availabil-

out in Mau's longer work, *Mute Compulsion*.⁴ The book is likely the best single summary of contemporary Marxist thought and serves as an invaluable resource for introducing the uninitiated to many of the foundational themes of communist critique and the character of economic power within capitalism. Though written in an accessible (albeit academic) style, the book nonetheless pays particular attention to relatively complex questions of how capitalist power operates via the metabolic divide between the human and non-human world, as well as debates about the necessary "reconfiguration" of prevailing technical systems which, because of their attunement to specifically *capitalist* production, also serve as mechanisms for social domination.

By contrast, the contours of the future society sketched in Mau's short article seem largely mundane. Communism is merely "freedom" and "democracy" applied to the economic sphere.⁵ In other words, the complex process of collectively reorganizing the species' social metabolism (a task that his book implies is fundamental to the communist project) is plastered over with simplistic panaceas that seem to be derived from the same philosophical wellsprings as those of the original utopian socialists—who, according to Engels, envisioned communist society as essentially "a more logical extension of principles laid down by the great French philosophers of the 18th century." We will thus draw on

⁴ Søren Mau, *Mute Compulsion: A Marxist Theory of the Economic Power of Capital*, New York: Verso, 2023

⁵ It is likely that Mau has simply erred too much on the side of accessibility in seeking to communicate the basic communist outlook to an unfamiliar audience. Since ideals such as "freedom" and "democracy" or dyads such as the "individual vs. society" and "private vs. public" are widely understood, these are easy ways to translate more critical concepts into colloquial terms. But translation always risks a certain vulgarization, and it simply isn't clear why Mau—a philosopher—would not give some signal that these are troubled and contested categories that have largely been monopolized by liberal thinkers. Another possible explanation is the fact that the piece was originally written for a Danish Social Democratic newspaper where Mau has a regular column.

material from Mau's longer and more rigorous theoretical work to argue against the practical vision of communism sketched out in his shorter article. Though this procedure is somewhat ironic, its purpose is to highlight the fact that even rigorous theory can reproduce ideological mystifications when its authors attempt to translate it into seemingly practical schemes without applying the same rigor to that process of translation and to the emergent complexity that arises from the messy interweaving of technical and theoretical questions within the practical sphere.

At the most basic level, we do not disagree with Mau about the minimal conditions for a communist society. In explaining what communism is, Mau defers to two leading theses, provided in the title of his piece and in a subheading, respectively: "Communism is Freedom" and "Communism is Democracy." These are more accessible, albeit easily mistranslated, ways of arguing that communism is a society organized according to the principle of non-domination. Here, Mau is alluding to Marx's own debt to the radical republican tradition. As William Clare Roberts explains: "The principled commitments of socialism, according to Marx, are not to equality and community, but to freedom—conceived as non-domination—and to the association that secures and expresses this freedom."⁶ In other words, rather than a more positive view of freedom "as individual or collective self-mastery," Marx emphasizes a negative view, where the social domination that defines capitalism (and all class societies before it) can only be fended off by the creation of an "association of free and equal producers," described by Roberts as "republicanism in the realm of production"⁷ and by Mau as "democracy" extended to the economic sphere.

Regardless of how much weight we place on Marx's debt to radical republicanism or whether an "association of free and equal pro-

⁶ William Clare Roberts, *Marx's Inferno: The Political Theory of Capital*, New Jersey: Princeton University Press, 2016. p.241

⁷ *ibid*, p.251

personnel to pick up the motors they need for a given production cycle at will. In some places, depot administrators might choose to offer last-mile distribution by means of their own choosing. In other places, there might be dedicated delivery associations that could mediate between the workshop and the depot. For most needs, these logistical solutions will be malleable and often informal—maybe a local group of equestrians has founded something like a "pony express," or some local artist/enthusiast ("madman," according to neighbors) has become particularly ("obsessively," "unhealthily," "quite unnecessarily") focused on building a strange system of pneumatic tubes spanning a large portion of the city. Maybe some individual operating one of the depots simply enjoys the activity of delivering motors. Maybe this individual is someone of a particularly bizarre character. Maybe they deliver motors to those who need them but also to those who neither need nor want the motors. Maybe they are known for devising elaborate distributional schemes that serve little apparent purpose—dressing in a bright red suit and dropping motors down chimneys, dumping piles of them into abandoned lots at the edge of town at night, placing the motors in a saddlebag and attaching the saddlebag to the back of a sedated boar that is then released in the wild so that anyone who wants the motors has to hunt it down—these are things that this individual considers fun, or possibly significant in some artistic or religious sense. Maybe this person enjoys the soft, insectile hum of the tiny machines. Maybe they construct eldritch sculptures out of them, left alone in the desert where they sit as unseen, whirring monuments. Maybe this individual crafts grotesque little toys out of the motors and leaves them hidden in inappropriate places for people to find, to their great displeasure. Art, play, madness, and purpose intermix.

Both the large motor producers supplying the depots and the smaller workshops sourcing motors from the depots will likely use designs accessed via some sort of distributed digital network (i.e., some sort of communist internet) where relevant information is

We can assume that communards will manufacture this motor in high enough volumes to supply regional demand. Most motors would thus be sent to electronics depots dotting the region from which anybody can come and grab the motors they need in smaller quantities. Some sort of regional depot distribution model would likely make the most sense because a significant portion of the final products containing these motors would be created in small quantities in more flexible local workshops. On the other hand, associations manufacturing goods that require these motors in medium or high volumes may order them directly from the association that assembles the final motors, skipping the depot and working out the shipping details on a one-to-one basis. In either case, the number of motors made in a given time frame would be determined by expected demand modeled by the associations managing the depots plus the demand from associations ordering in bulk. Buffer quantities would also have to be kept on-site at the depots in case of sudden spikes in the desire for motors, but, should desire rise suddenly to very high levels—maybe a new fad has taken hold among young people who enjoy wearing motorized propellers installed in gaudy hats, which all the older people think looks entirely idiotic—then communards may simply have to wait until the next production cycle, since a bottleneck in magnet or copper wire production is reached due to environmental limits, or, as the elderly are apt to point out, to “those damned kids and their stupid fucking hats.”³⁵

Individuals or associations who frequent certain workshops or groups of workshops concentrated in an area could send their own

³⁵ There is of course the obvious caveat that certain uses might be deemed critical in certain contexts and prioritized over those deemed to be spurious. Should a spike in the desire for motorized propeller hats threaten the availability of motors for crucial medical equipment that needs to be replaced after a natural disaster, for example, then it is conceivable that an arbitration association or disaster recovery association would broker an agreement between the motor manufacturing association, the medical device assemblers, and regional depots to prevent tragedies arising from supply shortages.

ducers” offers an adequate summary of what communism aims for, “non-domination” will serve as an extremely useful, “good enough” shorthand to describe the minimal guiding principle of a communist society. And it allows us to make a further point: communism is not a “final stage” of human social organization that is attained at a particular point in the development of the productive forces, but has instead, in a certain sense, haunted the entire history of class society. We can even say that the “communist idea” has stoked revolts against social domination and inspired (now long-defeated) forms of egalitarian social organization all the way back to (and well before) antiquity.⁸ The theme of non-domination thereby allows us to trace a red thread through various egalitarian struggles across human history.

But both the acephalous anarchist societies that once existed and all forms of communist struggle against pre-capitalist class systems were positioned within a material world where the human metabolism with nature was still largely a local affair defined by forms of subsistence production that relied directly on proximate ecosystems. In this period, subsistence production provided both the source of power for pre-capitalist ruling classes and served as the condition of possibility for various forms of egalitarian separatism. The emergence of capitalism and its encirclement of the

⁸ The political contours of this argument are made by Alain Badiou. But its historical character is made clear in modern archeological evidence, which has displaced the old notion that hunter-gatherer societies were predominantly small-scale and egalitarian forms of social organization that were displaced wholesale by hierarchical, grain-producing states after the agricultural revolution. The basic archeological and anthropological argument is laid out in: David Graeber and David Wengrow, *The Dawn of Everything: A New History of Humanity*, New York: Farrar, Straus and Giroux, 2021. However, Graeber and Wengrow’s overall narrative rejects basic materialist analysis in favor of a muddy historical idealism and often deploys questionable rhetoric in the place of rigorous argument, as Walter Scheidel has pointed out in: “Resetting History’s Dial? A Critique of David Graeber and David Wengrow, *The Dawn of Everything: A New History of Humanity*”, *Clodynamics: The Journal of Quantitative History and Cultural Evolution*, 0(0), 2022.

Earth has now irrevocably changed these conditions. One consequence is that the basic prerequisites for any communist society have taken on a new and elevated degree of complexity—and it is in this sense that “communism” proper is born (i.e. a “modern” or “Marxian” communism), as a vision of an inherently global society that requires forms of deliberation and planning that far exceed what is feasible at local scales, some of which will necessarily be planetary in scope.

In his book, Mau himself summarizes the fundamental features that distinguish capitalism from the forms of social domination that preceded it: precapitalist class societies ultimately relied on extracting some surplus from producers who were still intimately connected to the means of production (e.g., extra grain taxed from peasants to fill the granaries of the empire, with the remainder serving as the source of subsistence) and for whom the production process was relatively transparent. But, within capitalism, power operates through a “cleavage of the human metabolism” that separates producers from any direct control over the means of their own subsistence, which they can now only access via a competitive system of property that has been wedged within (and which widens) this metabolic rift.⁹ Since a small fraction of the population owns most of this property—especially the tools, land, and other infrastructure necessary to produce the things that keep people alive and society functioning—the majority must then work for money in order to secure their own survival. And working for money also essentially means working under the command (however indirect) of the relatively small group of people who own most of the resources of society. Mau explains that, within capitalism, “class domination therefore refers to the relation between *those who control the conditions of social reproduction* and *those who are excluded from direct access to the conditions of social reproduction*.”¹⁰ Amadeo Bordiga, co-founder

⁹ *Mute Compulsion*, p.321

¹⁰ *Mute Compulsion*, p.129, italics in original.

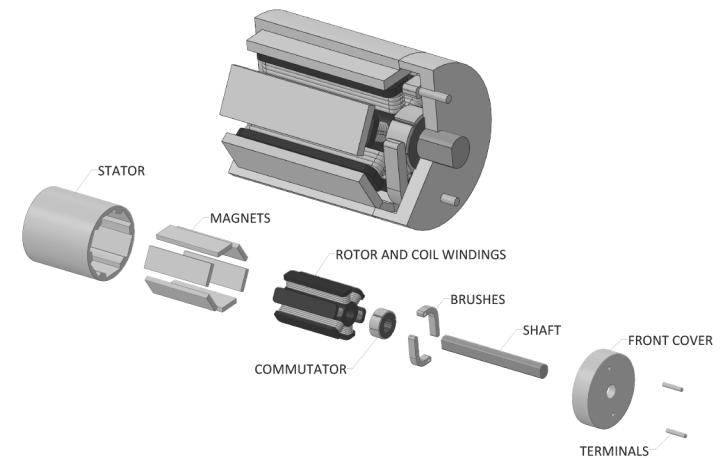

Figure 1: Schematic of a small brushed DC motor, somewhat simplified

Source: Authors’ design

currently found in goods such as electric toothbrushes, electric shavers, and smartphones. Such motors have several key pieces:

- Armature: a frame around which copper wire is wound in a specific fashion in order to generate a suitable magnetic field
- Magnets whose fields push against the field generated by the armature
- Brush and commutator: electrically conductive pieces that continually flip the polarity of the winding's magnetic field as the rotor turns, enabling continuous rotation
- Outer casing which often doubles as the stator

It is not critical for the reader here to understand the details of exactly how electric motors work, only that even simple ones are assembled from a variety of components, each one of which is itself an output of complex industrial processes.³⁴ A small brushed DC motor is sort of like apple pie: in order to make one from scratch one must first create the universe. To make things simple our speculation will be limited to the fabrication and assembly of that which actually comprises the physical motor itself, not including its components—which we presume are sourced from upstream associations in various ways similar in kind to the methods used to distribute such motors to their own downstream uses.

³⁴ One good visual overview of contemporary motor assembly can be seen in this video, which shows a motor production line operating in China. The motors manufactured on this line are a different kind than what we describe here: they are larger and feature coil windings on the stator instead of magnets. Nevertheless, this video demonstrates the technical complexity of motor manufacturing and the particular character it takes under capitalism. One of the features of the process that stands out is how much of the routine labor involved currently consists of little more than shifting and arranging components as they pass between various machines.

of the Italian Communist Party, offers an even more succinct definition: “[...] from the moment in which wages are paid in money and with this money you buy food, you have capitalism.”¹¹ Communism would therefore require the abolition of money and the market system that it represents, since these are the material underpinnings of the specifically capitalist form of social domination that has wedged itself in the metabolic gap between the human species and its means of subsistence.

But capitalism is also unique in the degree to which it transforms both sides of the metabolic gap, irreversibly modifying the non-human world and making the human species increasingly dependent on complex and increasingly opaque technical systems for its survival. This has serious political implications. For Marx, accurately appraising the significance of the advent of modern industry was precisely what distinguished communism from the schemes of the older utopian socialists who advocated various forms of “worker separatism” rooted in the revival of artisanal forms of production at a distance from the capitalist system. In other words, the utopian strategy was to exit capitalist society or retreat to its edges and either peaceably build a new world in these settler colonies or use them as launch pads to combat capitalist decay from the outside. But Marx argued that modern industry and the associated build-up of state power doomed such a strategy from the outset. As described by Roberts:

The development and advance of the capitalist regime, [Marx] argues, eradicates every condition of independence. It makes each laborer dependent upon untold others. It destroys the skills necessary for independent production and propagates a taste of the good things

¹¹ Amadeo Bordiga, “Lessons of Counter-revolutions,” in Pietro Basso (Ed.), *The Science and Passion of Communism: Selected Writings of Amadeo Bordiga (1912–1965)*, Chicago: Haymarket, p.275

that can come only from cooperative labor on a massive scale.¹²

However, contra a certain accelerationist subgenre of utopianism today (that of the “post-scarcity” or “full automation” type), this does not mean that capitalism is necessary in any *positive* sense: “Nowhere in *Capital* does [Marx] argue or imply that capitalism has developed human productive powers to the point where we can meet everyone’s needs, or that such a development would constitute a threshold before which the attainment of communism would be impossible.” Instead, capitalism has reshaped the conditions of class conflict and the prospects of a communist society in a largely *negative* way: “on the one hand, by destroying the laborers’ capacity for going it alone, and, on the other, by creating disasters so immense in scale that only massive collective efforts could possibly address them.”¹³

While capitalism does not create the necessary positive conditions for communism, it does create negative necessities in the form of qualitatively new challenges that communist struggle must overcome. In other words, it reconfigures the basic conditions of possibility for a communist society. Because of the vastly transformed material metabolism that capitalist production has imposed between the human species and the non-human world and because of the intricate ways that social domination has woven itself into this metabolism, non-domination remains a necessary but no longer a sufficient definition of the communist project. Pre-capitalist forms of domination operated largely via direct control over people, land, and the basic material outputs of production (namely grain and livestock, but also foraged materials and wild game). Social power was essentially gleaned from the surplus that foamed atop otherwise local pools of subsistence. Similarly, various anarchistic or customary social orders were

¹² Roberts 2016, p.193

¹³ *ibid*, p.171

nature of associations would allow them to attune requests for particular artifacts to the heterogenous nature of these artifacts themselves. Here, a concrete (albeit entirely speculative) example will help to illustrate the basic idea.

The Motor of History

There’s something special about circular motion. Millennia before we could describe it with calculus, graph it sinusoidally, or figured out the utility of π , people were moving things at a fixed radius around an axis. Whether it is the turning of a cart’s wheel, the spinning of clay to make pottery, the rotary crushing of grain with a water mill, or even the circularity of cosmological calculation, the ability to move things in a circle is foundational to human technology. Capitalism has not changed the critical character of circular motion, and communism is unlikely to usurp it either. Thus it is possible to speculate about how communards of the future might manufacture one of the biggest success stories of circular motion: the electric motor.³³

There are many different types of electric motors all suitable for different use cases with various technical tradeoffs. For our purposes we will consider a small brushed DC motor like those

³³ We have chosen to be purposefully conservative with this speculative exercise in terms of imagining what sorts of technologies and materials would be available to communards. It is almost certain that decades of communist R&D guided by logics not beholden to capital will create productive methods quite different from what we can imagine at this present moment. It may well be that novel biosynthetic methods of chaining ATP production to the generation of raw electricity will make it possible to generate “living” engines of a character presently unimaginable, for instance. But attempting to speculate on such technologies too easily elides the basic problems faced by deliberation within the productive sphere, serving as a sort of magic wand that would do away with the messiness of the manufacturing process. We will therefore speak of the electrical motor largely as we know it today.

cific request is shunted to the next production cycle if one of the deliberative limits is hit. Though priority lists might have some overlap with our idea of “essential” vs. “non-essential,” they would more commonly indicate things like seasonal demand (prioritizing sweaters in the fall for temperate climates) or temporarily crucial needs (prioritizing construction materials to areas recovering from earthquakes). The majority of them would not even be matters of mass manufacturing, but instead local affairs set by deliberation within routine associations devoted to meeting relational needs—things that today might be summarized as very broadly “reproductive,” ranging from cooking food to trimming trees, sweeping streets, raising children, or constructing the built environment.

These negative limits could operate alongside any given algorithm for the allocation of goods. If we presume that the exact way information is input and transmitted will vary widely, then we can understand this positive side of the plan as a cascaded heterogeneous system. Planning can be broken into cycles based on certain presumptions about production time and the life of the artifact. A rolling forecast could be continually generated by associations and/or by final users themselves, organized in any number of ways—the precise technical method being attuned to the nature of the materials in question, the functional capacities of involved associations, and the cultural practices prevailing among those making the request—the summary of which would then cascade back up the production chain via whatever algorithmic means the relevant associations choose to use until it reaches the producers of primary raw materials. The quantity of a raw material produced would then either be the amount specified in this forecast or the established limit for the use of that particular resource from those particular sources or in that particular area (or, of course, globally), whichever is lower. The basic idea here, however, is that the very process of deliberation makes it possible to cascade production in this way even in the absence of some universal “protocol” or single, homogenous information system such as “price.” The deliberative

able to persist at a distance from hierarchical societies (or in the wake of their collapse) because local subsistence could still serve as the material basis of their independence. At a purely technical level, this is simply no longer possible—unless we take as a precondition for our political program the mass die-off of the bulk of humanity.¹⁴

But the problem is not just a technical matter of whether local subsistence can or cannot be reinvented. Under capitalism, social domination is now inscribed *within* the productive mesh that bridges the metabolic gap. This means that non-domination must now be etched into the metabolism of the species at that same scale. Even reduced to the simplest possible measurements, this scale is gargantuan: the total mass of the “technosphere” constructed by humanity, visible in our enormous infrastructures of concrete and steel, is now roughly equivalent to the aggregate biomass of all life on earth.¹⁵ Industrial agriculture has led to the systematic degeneration of soil quality and rapidly accelerated the planetary nitrogen cycle.¹⁶ And, of course, the climate has now been irreversibly modified by fossil fuels burned to serve the imperatives of capitalist production. At the social level, reconfiguration now also requires uncovering, untangling, and ultimately undoing the much more intri-

¹⁴ And even if the world were to revert to such an order, this would seem to merely result in yet another historical repetition, with capitalism or other forms of social domination soon rising from the ashes to reconquer the world. After all, these pre-capitalist forms of communism proved unable to mobilize the material and political force necessary to decisively defeat pre-capitalist forms of social domination, to prevent capitalist society from emerging in the first place, or to stall its advance. Maybe this was not foreordained, but it is a plain historical fact. It is only this *political* sense that we might think of them as “primitive.”

¹⁵ Emily Elhacham, Liad Ben-Uri, Jonathan Grozovski, Yinon M. Bar-On, and Ron Milo, “Global human-made mass exceeds all living biomass”, *Nature*, 588, 2020. pp. 442–444.

¹⁶ Jan Willem Erisman, James N. Galloway, Sybil Seitzinger, Albert Bleeker, Nancy B. Dise, A. M. Roxana Petrescu, Allison M. Leach and Wim de Vries, “Consequences of human modification of the global nitrogen cycle”, *Philosophical Transactions of the Royal Society B: Biological Sciences*, 05 July 2013.

cate means by which domination is upheld—especially the abstract time-discipline of work and wage. For all these reasons, communism can no longer merely be defined as non-domination. Instead, a communist society is one in which non-domination is made possible by material abundance and free time ensured through the application of science to production and through cooperative methods of social deliberation and empowerment that penetrate all the way down into everyday life and all the way up into novel systems for managing the planetary metabolism. For Marx, recognition of this point served as *the* crucial political division within the early socialist movement because it separated schemes that were doomed to simply reproduce capitalism or be crushed by the state from those that had some prospect of building a communist world.

Localities

Today there is still an unfortunate tendency to think that a post-capitalist society must be characterized by an inward turn towards localized forms of living. Refuge from the global market is assumed to be found in its opposite: non-market (or mixed-market) systems where everything is produced and consumed as locally as possible. For example, Mau envisions the following:

Let's call the basic unit of the institutional structure of communism the commune. Everyone would have to choose a home commune, but everyone would be able to live in whatever commune they would choose. Communes would vary in size, depending on their revolutionary prehistory as well their particular geographic, cultural, and historical context. Some communes would be heavily urbanized and count their inhabitants—let's call them communards—in the millions, while communes in sparsely populated areas

producing rice paddies, or on the total number of livestock that can be raised within a given timeframe. These limits would then propagate down through the nested structure of the largest associations to provide guidelines to local branches.

We can even presume that limits would be set with the presumption that such guidelines are not universally followed. In other words, each “limit” would also have something like a compliance forecast based on historic trends or the technical characteristics of certain sectors where it might be more difficult to modify existing output patterns. It would obviously be important for associations to investigate the causes of non-compliance—which may be entirely reasonable—and there would have to exist forms of social arbitration led by associations specializing in conflict resolution to explore solutions to the most difficult or persistent cases of local non-compliance.³² But the basic idea here is that limits would ultimately be broad and minimal constraints operating in a context of general abundance, rather than rationing systems dancing around some fundamental, life-or-death scarcity in essential resources. True scarcity in anything other than fashionable curiosities is something that would belong to the earlier phases of communist construction and would have to be solved through some sort of equitable combination of lottery, scarcity-weighted distribution, and voucher-like systems for determining work requirements.

Within communist society proper, associations might, at most, choose to grade certain goods by degrees of priority, determining the sequence in which a certain good is allocated or which spe-

³² It also seems quite obvious, however, that an association which chooses to erect a giant coal-burning facility for entirely selfish and parochial reasons would likely be treated with a similar level of hostility as one that decides to dump poison into a water supply. But, again, by refusing the inherently communitarian locality-based social organization, the system of free association would tend to undercut the formation of such parochial desires in the first place. By contrast, communitarian models of communism would seem to generate parochial interests as a matter of course.

the bulk of mass and energy passing through the entire industrial system, serve as the most direct interface with the non-human flow of materials through the major geospheric systems, and have the largest social impacts on things like population distribution and cultural practice. Second, if social and metabolic stewardship is already accounted for at an initial level of production, it means that practitioners of all productive processes downstream from those in which limits are imposed are at liberty to produce whatever they want with those materials at whatever level of free association they choose to do it at without having to expend a lot of time calculating the entire social-ecological footprint of the artifact they are seeking to manufacture. They would instead only be responsible for appraising special or unaccounted-for impacts of their specific artifact: additional waste generated by a manufacturing process, the recyclability of the materials, potential impacts on public health, etc.

Limits could be set for a given material under the assumption that the material would be used up in its entirety within a certain timeframe, with all the associated ecological consequences. For instance, even with optimistic presumptions about electrification, carbon-capture, or the emergence of novel “green” production techniques for the most widely used industrial materials such as concrete and steel, a certain amount of greenhouse gas emissions is going to be unavoidable and would need to be balanced with the forecasted capacity of carbon sinks and direct-air-capture facilities to ensure that total emissions remain negative—if we presume that the process of drawing down the greenhouse gasses emitted during the capitalist era is still ongoing. Thus, if the planetary climate association concludes that global greenhouse gas emissions must remain below a certain annual threshold, then limits could be placed on the amount of fossil fuels that can be allocated to upstream uses—rather than downstream activities where emissions are difficult or impossible to measure—on the amount of biomass that crop-growers can burn or allow to rot, on the acreage of methane-

or desolated islands could have very few inhabitants, at least to begin with. [...]

Ideally, each commune would control everything necessary to cover the needs of its communards, from land, water, energy, and other natural resources to labor power, technology, research, and education. Decisions should generally be made by—or as close as possible to—those affected by them to ensure a high degree of autonomy and minimize the risk of undemocratic centralization of power.

Mau immediately follows this vision with the disclaimer that “in practice, this is an ideal impossible to realize, partly because one of the basic conditions of all communes is a stable biosphere, and that can only be guaranteed through some sort of global regulation of the use of our common natural resources.” Mau also admits that this vision exists in tension with the need for some affairs, such as ecological concerns, to be organized in a globally cooperative manner. He posits that there could be cooperation between communes in a way that “would likely result in some sort of pyramid structure consisting of political institutions with decision-making power as well as forums for coordination, knowledge-sharing, and reciprocal aid.” But the vision remains largely local.

Frankly, Mau’s “communes” seem to be more or less miniature countries. His vision of communism takes the basic ideological image of society that we already have—that of a world governed by territorial divisions that map onto cultural, administrative, and economic ones—and simply reproduces it at a more granular scale. If we were being uncharitable, we might even suggest that these localist visions bear some resemblance to right wing forms of communitarianism. Throughout the world, the right has long invoked similar visions of local self-reliance, and nationalists have often pushed for smaller territorial units more attuned to minute differences of language and culture. Communists who advocate for

local systems of production and administration must therefore explain how their schemes would not simply reproduce the various forms of exclusion and xenophobia inherent to these communitarian projects. Most attempts to avoid these outcomes imply the need for institutions of an entirely different scale, which usually remain somewhat murky—often a vaguely-defined “confederation” or something like Mau’s gesture toward a “pyramid structure.” For example, since Mau argues that everyone would be free to choose their “home commune” and allowed to “live in whatever commune they would choose,” the implication is that there would exist some sort of higher-order power able to prevent locales from excluding outsiders—even if this exclusion was democratically decided by the locality.

Ultimately, then, “democracy” does not adequately describe the forms of power and deliberation that would have to prevail in a communist society, nor does the locality serve as the natural or given administrative unit of this deliberation. However, our principle objection is not to localization *tout court*, but rather to the idea that “land, water, energy, [and] technology” can or even should be controlled locally. At the purely technical level, the reality is that very few of these things can be localized to a city-sized commune in a fashion that would actually provide for modern population sizes. Even assuming a given commune has large tracts of arable land, ample reserves of freshwater, and good renewable energy amenities, none of these resources can be efficiently utilized without modern industrial technology that is, on average, extremely difficult to localize. Good luck building and maintaining a water purification plant with no inputs from outside of a 200km radius!¹⁷ The

¹⁷ Most water treatment is conducted through some combination of filtering, UV exposure, and “flocculation” (mixing after adding a chemical coagulant that bonds to solids making them easier to separate). To build such a plant, you need rudimentary inputs like cement, copper, and steel, alongside more advanced electrical components for the UV lights and more complex membranes and machinery for the filters. But even if you were to come into control of an already-

tion. The more fundamental issue is a simultaneously social and ecological one: how to steward the human metabolism with the biosphere and other planetary systems in a fashion that does not narrow free time to such an extent that a new form of alien social compulsion dictates human subsistence? The deliberative process of setting limits on production seems to be the most likely way to reconcile these conflicting imperatives.

Unlike a quota that requires certain numbers of finished goods be produced, limits could instead be implemented at the level of basic materials fabricated far upstream from finished goods themselves. After all, one of the defining features of a communist society would be the decoupling of basic human satisfaction from the need for constant “growth.” As early as the 1950s, Bordiga suggested that a modern version of the demands at the end of the Communist Manifesto would necessarily include something like an “underproduction plan” that emphasized the “de-investment of capital,” resulting in an overall reduction in the volume of production and prioritization of goods for direct human use over those intended to expand productive capacity. The deliberative apparatus of industrial-ecological planning would therefore not be a Promethean machine that reduces scarcity by driving the power of the productive forces to ever-greater heights, but instead an apparatus for scientifically stewarding abundance while also reigning in productive capacity such that it does not spill out into unrestricted squandering of mass and energy by the species. In other words, the “plan” would not be a matter of scrambling to meet quotas with limited resources at hand but instead the basic practice of tending to something like a productive permaculture that is always technically capable of generating more than what is needed.

There are two technical reasons that administering production according to limits rather than quotas would also be beneficial. First, in most cases it is far simpler to account for the social and ecological impacts of energy generation, food production, or resource extraction than final assembly. These upstream activities absorb

therefore, prone to erode and mutate in the course of constructing communism. Rather than projecting these conventional categories forward in time such that they can serve as the positive basis for communist planning, we would instead propose a minimal vision which emphasizes the negative aspects of productive administration: instead of clearly delimited industries meeting production quotas for specific goods (or simply divided between scarce vs. abundant or essential vs. frivolous), we can imagine an industrial-ecological infrastructure managed according to production *limits*. Just like the associations of producers that manage them, these limits would be functional and deliberative in nature. In other words, instead of deciding exactly what to produce, associations would instead be tasked with deciding what *not* to produce.

“Demand” for goods can be managed in any number of ways. Probably the option most familiar to us would be something like a digital ledger through which requests are placed, logged, and fulfilled, putting those who need a certain good in communication with those capable of producing and transporting it—essentially the communist equivalent of an e-commerce platform like Amazon or Taobao. Different variations on this theme tend to feature strongly in the sort of algorithmic solutions advocated by the “digital socialists” that Benanav is responding to: “they want to design software that can take in information on consumer preferences and industrial production capacities—like a gigantic sieve feeding into a data grinder—and output the optimal allocation of resources.” But it’s equally likely that actual production and allocation would be coordinated in new, unfamiliar, or even seemingly archaic ways, with many goods in what Mau would call the “private” sector not “exchanged” but rather obtained through novel types of play or via difficult to understand (for us) channels affiliated with new and emerging local cultures. The problem is therefore not primarily the algorithmic issue of demand and distribution treated by the classic “socialist calculation debate.” There are numerous *technical* solutions to the “problem” of adequate information and timely alloca-

same can be said for other necessary infrastructural technologies such as solar panels, hydroelectric dams, tractors, sewage pump stations, and more. This is just as true, in many cases more so, for non-infrastructural but equally essential technologies such as microelectronics, pharmaceuticals, metal fabrication, etc. There are cases where it may make sense to revive “archaic” technologies for social purposes: for example, meeting demand for certain local goods like furniture via the revival of local artisanal skills. But even these industries would require base inputs of raw materials that would exceed local supplies as dictated by ecological limits. If “technology” is to be created at the commune level, then most of Mau’s communes would be limited to technology no more sophisticated than that of medieval Europe. And this would require a massive reduction in the world’s population.

Such technological constraints mean that processes requiring inter-commune cooperation would not be an exception to the localized norm, but rather the productive precondition for the type of

existing water treatment facility, you’d need to secure regular supplies of crucial inputs for the flocculation and filtering process, namely chlorine, activated charcoal, and aluminum sulfate. Chlorine is produced through an electrolysis process that requires inputs of salt solution as well as advanced polymers to serve as membranes. Activated charcoal is produced by treating carbon inputs (anything from coal, to coconut husks, wood, peat, etc.) with extreme heat. Aluminum sulfate can be synthesized from clays and certain other geologic sources (alum schists or cryolite) but is most commonly produced through a reaction of aluminum hydroxide (mostly derived from bauxite) and sulfuric acid (which requires sulfur, most of which is currently derived from the hydrogen sulfide produced in fossil fuel production). Currently, the process is extremely capital intensive and makes the most sense to conduct at large scales, meaning that aluminum sulfate production is heavily concentrated in just a few plants. As of the late 2010s, there were a mere six aluminum sulfate plants in the entire US west of Corpus Christ, TX, and none in the entire Pacific Northwest, according to the EPA. Reverting to a boiled-water purification system (today widely in use in many of the world’s poorest cities) is not a scalable solution, nor is it compatible with integrated sewage treatment systems. The current process used for water treatment is certainly not the only possible one but it does illustrate the geographic scale and technical difficulty involved in any attempt to purify water for millions of people.

communist freedom that Mau gestures toward. This, in addition to the aforementioned problem of ensuring non-domination, implies that the crucial social relationships—those necessary to ensure that certain fractions of the population are not dominating others—are not those within localities but rather those that prevail between them. Inter-territorial relationships and industrial systems would be the foundation for locally contained social arrangements, rather than the other way around. This is not to say that all production must be a centralized global affair. We agree that much more production should be localized and that the revival of various “archaic” artisanal and ecological skills should be a priority. One of the major “anthropological” tasks of constructing a communist society is to ensure that both personally and socially fulfilling forms of productive and ecological knowledge are cultivated at the most foundational levels, restoring lost or atrophied capacities to a species mutilated by the demeaning machine-logic of capitalist production. Relatively labor-intensive forms of ecological stewardship and the increasing localization of food production are technical prerequisites for the larger tasks of environmental restoration, which ultimately scale up to planetary imperatives such as the administration of emissions or the management of the nitrogen cycle. Such skills can only be learned through practice and are often better learned at the local level.

Even where local administration makes technical sense, we can envisage local productive and agroecological knowledge being revived less for technical reasons and more to serve a social function—as part of a much larger apparatus for (simultaneously individual and social) cultivation and transformation. But an equally important part of this larger process of productive cultivation would be the learning of abstract forms of knowledge—in say, the natural sciences—and active participation in collaborative and cooperative systems of ecology and industry spanning many localities. To call such a revival of widespread practical knowledge “artisanal” can thus be a misleading metaphor. The point is that the

is contrary to any communist orthodoxy rooted in the works of Marx, but which nonetheless became common through the now long-dead “Marxist” dogma that formed around the Russian experience and remains petrified in popular ideology today. But even Benanav is not entirely clear on the question, simply suggesting that a socialist society is one in which a “realm of freedom” would be progressively enlarged, allowing more “space for radical experimentation that could be explored by all, without endangering anyone’s material security or individual freedom.” Mau, by contrast, seems to completely elide the question, fully equating communist society as such with what seems to be a more rudimentary social order (effectively a “socialist market economy”) in which a “public” sector devoted to activities necessary for social reproduction would remain divided from a “private” sector in which “products that the commune has opted to not include in its economic plan” would be manufactured and exchanged by people in their free time—even suggesting that money might persist in order to coordinate this activity.³¹

In this sense and this sense alone, we might argue that the problem of the utopians is that they fail to be utopian enough. Battles between “needs” and “wants,” between “scarcity” and “abundance,” between “freedom” and “necessity,” and between “public” and “private” tend to plague such accounts—forming the standards against which various forms of “planning” are concocted—despite the obvious ways that such categories are socially constructed and,

³¹ It might be argued that, rather than a picture of an actually communist society, Mau is effectively offering a view of some sort of near-term period of communist construction in the same fashion as Benanav. In this case, however, the utopian sketch becomes even less relevant to reality, since it abstracts from the very issues that are central to the earliest phases of communist construction: ongoing combat against the remaining capitalist world, the need to guard against an unconscious revival of social domination among the billions of people for whom things such as “money,” “property” and an “economy” seem to be God-given features of any social organization, and of course the entire political process of continuous social transformation.

assigned to scarce necessities) are being inexorably wiped away without regression. In general, commonplace fears around the term “communism” relate almost exclusively to the period of active revolutionary struggle, with its risks of scarcity and necessarily forceful means of defense and continual expansion of the revolution beyond its initial barricades. The difficulty is therefore not explaining the simple utopia of how a communist society might function at its higher levels, but how it might ever be able to emerge from these constrained, lower phases. This is where all the messy debates about strategy, authority, and means vs. ends are gathered. But, even after the civil war is won, the social war continues, marking the transition from the earliest, revolutionary period of communist construction to the subsequent “lower phase” of communism, during which the associations gestated in the revolutionary period begin to bloom. Meanwhile, the “higher phase” of communism should be understood not as the “completion” of communist society but instead something more like its birth, initiating an entirely new period of evolution for the human species. Communist construction—the gestation and emergence of communism from a non-communist body—is continually giving way to communism, plain and simple. Eventually, there is no longer any necessity for “vouchers” tied to labor or anything else that resembles money or “value.” Everyone takes what they need regardless of how much work they do or what type of work they do.

Utopian visions often suffer from a tendency to conflate certain features of these “lower” gestation periods in which communism is constructed with the practices that would prevail in the “higher” phase when communist society is a living reality. This often helps to make the basic spirit of a communist society visible and accessible to a general audience. For this reason, it is sometimes common for certain utopian visions to deploy slightly different terminology. Benanav, for example, refers to his sketch as that of a “socialist” society, indirectly invoking the idea of socialism as a sort of lower stage society that precedes a fully communist one—an idea that

productive subjectivity of the species would neither resemble the fragmented and mutilated kind found in the modern proletarian, nor that of the craft peasant hamstrung by the labor-intensiveness of basic subsistence. Instead, communist productive subjectivity would be a melding of both practical and abstract knowledge in a historically unprecedented form.

Moreover, the inputs necessary for even localized forms of production would commonly originate from processes that only ever make sense to structure as mass-manufacturing lines which both provide goods for and receive inputs from very wide geographic areas. Below, we will explore some technical aspects of what this production might look like. But the technical characteristics of production are, ultimately, secondary. They provide certain material limits, channels, or potentials that must be chosen through some process of social deliberation. For Mau and, we would argue, the vast majority of similar utopian fables, the problem is that these technical constraints are not even considered. The image of society that emerges is then one where deliberation seems to occur in a vacuum. Thus, despite Mau’s claim to be envisioning a situation in which “democracy” has been extended to production, politics appears to play out mostly in the traditionally “civic” spheres of neighborhood and city, rather than within any sort of industrial setting. In fact, the geographically delimited “commune” appears to have replaced the industrial sphere as such with something like the “civil society” idealized in liberal political philosophy. And it is only in this impossible context that some sort of pyramidal confederation of direct-democratic and geographically delimited communes makes any sense, because these communes have no function other than the vaguely-defined mandate to represent the interests of their stakeholders.

What, then, could serve as a form of deliberation adequate to the necessary scale of most production and ecological stewardship? First and foremost, we must resist the attempt to imagine that a communist society would be constructed “up” from self-

same atomic units, whether we envision these as geographic units or functional elements. As Roberts argues:

The precise institutional arrangements that will best suit any particular group of free and associated laborers will necessarily have to take into account the particularities of their situation, their common resources, their characters and histories and interrelations. The people best placed to know those particularities will be those free and associated laborers themselves.¹⁸

In other words, communism is not a social monoculture. Just as old forms of local agroecological subsistence provided a foundation for a wide diversity of social practices, so too would the new planetary productive foundation of a communist society induce a diverse efflorescence of new lifeways. The protracted process of overthrowing capitalism and constructing a communist world would itself produce a mosaic of new social forms through the chaos of the transition.¹⁹ Many communist institutions would likely be “exapted”

¹⁸ Roberts 2016, p.238

¹⁹ Another fundamental failure of most utopian visions is the fact that they treat his process of revolutionary transition and communist construction as largely incidental to the character of the communist society that is its ultimate result. Instead, we would argue that it is precisely the messiness of this process of revolution and reconfiguration that provides the real raw material (in both a technical and social sense) from which a communist world will be constructed. Readers interested in this aspect of the question will find useful material in a triad of articles by Jasper Bernes: “Revolutionary Motives” addresses the process of revolution itself, “The Belly of the Revolution” addresses the question of reconfiguration at the level of primary production, and “Logistics, Counterlogistics and the Communist Prospect” addresses the same issue at the level of contemporary logistical systems. To these we might add Alberto Toscano’s article on logistics to which Bernes’ piece was, in part, a response, and Toscano’s own response to Bernes’ logistics piece. Similarly, John Clegg and Rob Lucas’ article, “Three Agricultural Revolutions” engages with and addresses many of the same questions as Bernes’ “Belly of the Revolution,” as does the *Endnotes* article “Error.” We do

against the basic relationships that structure the capitalist world, which are crystallized in things like price and property.

The earlier phases of the process of constructing a communist society might require forms of conditional accounting to manage the turbulence of reconfiguration: methods of measuring labor time, material scarcity, consumption of goods, and the use of these measurements to determine distribution according to some system of priority. Communism is not constituted by these forms of accounting, but rather gestates in spite of them. They are temporary growing pains whose trajectory must always tend towards supersession by communist planning proper. The exact balance between necessity and experiment—between the civil war and the social war—will constitute the central strategic question of this earliest era of communist construction, determining whether the revolutionary project is able to pass through its first bottleneck. But these limits should not be seen solely as fetters on social transformation. Every limit is also generative.³⁰ Even while the practical constraints of the civil conflict might force partisans to, for example, maintain otherwise undesirable agricultural monocultures—since soil rehabilitation and the construction of new agroecological systems is an extensive undertaking in areas long devoted to the factory farming practices of contemporary agrobusiness—in other realms it is precisely these constraints that spur on the process of social invention crucial to the revolutionary character of the process.

Communist construction is ultimately defined by its character as a transition from one society into another, and this transition is successful only if the remnants of capitalist society, including temporary measures that may bear some superficial resemblance to wage or price (i.e., labor vouchers or priority distributional weights

³⁰ If we can be forgiven one completely fanciful philosophical reference, Hegel scholar Karen Ng has an excellent conference talk (available here) discussing the concept of the “limit” within dialectical thought and its relationship to the issue of social metabolism and “natural limits.”

will nonetheless take decommodification as a sort of baseline, dealing with initial shortages and even the danger of military repression without reinstating systems of money, property, or other forms of social domination—even if these things would, initially, increase “efficiency” in some sense.²⁹ In this way, the defensive civil war that follows from any revolutionary upsurge is only truly won through a more expansive social war launched

²⁹ Since money and markets both predate capitalism, the question of whether they can serve any purpose within a communist society is often a contentious one. There is generally consensus that any society in which people must rely on money and markets for the essentials of life (things like food, housing, clothing, education, healthcare, etc.) would not in any way be communist. Beyond this, there are (very loosely) two schools of thought. The first argues that, so long as money and markets are confined to “non-essentials” (or, more strictly “frivolous” or “luxury” goods), then they can be allowed to play some role. The second argues that money and markets must be strictly forbidden. In some cases, the prohibition is justified by (we would argue, mistaken) claims that any forms of money or market exchange invalidate communist social relations *in toto*. But the more practical position (and the one we take here) is simply that, while these forms can and have existed beyond capitalist society, they are nonetheless extremely dangerous. Limiting them to the “non-essential” margins is a challenge because they tend to take on an expansionary nature. Throughout history, market relations were largely insulated from the “essential sphere” (of local subsistence production) but also repeatedly ran up against this sphere. Eventually, markets and money broke through and established themselves as the basis of our social metabolism. Because of this, susceptibility to future spillovers is even higher. We might think of money and markets in much the same terms as a virus. Even if the virus is largely limited to some marginal vector species, repeated contact with that species can threaten a zoonotic leap which—if certain conditions are met—then allows the virus to propagate within the human population at a rapid pace. Those who claim that money and markets can be used within communist society must, then, account for how, exactly, these mechanisms would remain limited to their marginal uses without spilling over into the mesh of essential activities that compose the core of the social metabolism. For this reason, we argue that it is simply too dangerous to revive the use of money and markets even for “non-essential” sectors—though the risk could, conceivably, decline hundreds or thousands of years into the future, after communist society has advanced so far that it achieves effective immunity.

from the diversity of functional groups that arise for various reasons in the revolution and the subsequent “lower phases” of communist society. Ultimately, this means that we cannot hope to forecast these in any sort of detail, other than presuming certain negative standards (the absence of domination, the upholding of basic principles of voluntary association, proscriptions against unduly destructive ecological practices, etc.) that might be ensured by larger-scale deliberative institutions.

Association and Deliberation

Geographic institutions would certainly be a part of this. Rather than simply being scaled to population, however, associations would most likely be attuned to the functional “size” of particular ecological or technical systems—for example, a watershed and the water processing infrastructure that draws from and feeds back into it.²⁰ But, given the non-local character of most productive, reproductive, and ecological systems, we would assume that many of the most important institutions in both everyday life and for the social system as a whole would not be limited by locality. Against the geographic “commune” suggested by Mau, then, we

not necessarily endorse any of the specific conclusions made by these pieces. We would argue that Bernes, in particular, overestimates the degree to which capitalist social domination is baked into technical systems (in this limited sense, our position is closer to that of Toscano) and tends to make either completely untenable or simply overoptimistic presumptions about the pace and character of agro-ecological and industrial reconfiguration—often seeming to endorse many of the same localist errors as the utopian visions that we critique here. But the basic thrust of Bernes’ arguments are essentially anti-utopian, attempting to deal with the very real problems, material and social, posed by the process of transition. And in this sense they are required reading, initiating much of the debate we are engaging with here and inspiring our own formulation.

²⁰ Even though it is inherently geographic, the watershed is also notoriously difficult to “localize” to the level at which Mau’s “communes” would seem to operate. Watersheds are quite obviously nested into one another and local use of their resources raises questions of regional coordination.

might return to Marx's own notion of voluntary "associations" ("associations of producers," in the original, but only in the sense that the divides between industry and ecology, production and reproduction, and work and life have been eroded). Though necessarily vague, the idea of an "association" nonetheless foregrounds the intentional and cooperative nature of such institutions, which would be inherently *functional* rather than geographic. As Aaron Benanav argues in a similar utopian sketch inspired in part by the work of early 20th-century communist thinker and philosopher of science Otto Neurath: "what we need is not one society-wide protocol but many protocols — many structured forms of communication that enable people to reach decisions together." As we do here, Benanav also adopts the notion of "freely associated producers" to describe this diversity of "protocols" and similarly stresses that "coordination should take place [...] mostly within and between associations" which themselves "might be composed of producers, consumers, or other groups of people with common identities and interests."

We should not presume that associations would all necessarily be administered in a homogenous, direct-democratic fashion. As Benanav argues, "true democratic decision-making about production cannot simply be a matter of a perpetual social-media plebiscite scrolling across one's phone screen—for the simple reason that many individuals lack the practical knowledge necessary for making most production decisions." Instead of "democracy," which to most readers implies something ranging from direct-democratic consensus to systems of representative government administered according to majority rule, we imagine that communism would be administered through a range of "deliberative" systems irreducible to these archaic forms of "democratic government"—which have, from their very origins, always served as a disguise for elite rule. Mechanisms such as voting, consensus, and representative delegation would likely be a part of many of these deliberative practices, but such practices

tion persists in the poorest areas precisely because this food cannot be *afforded*—and it is this "priced" scarcity that forces most of the population to work for others in order to survive. Thus, the idea that the "price" must be replaced by the "plan" is fundamentally backwards. "Planning" is already a part of pricing, used in the forecasting of production within major corporations, in the implementation of vast logistical systems to cut down costs and discipline labor, in the conventional practices of corporate accounting, etc. In fact, it is not "prices" but orders and their ensuing flow that currently provide the information necessary to allocate resources within and between capitalist firms. Planning occurs in all forms of production. The relevant question is not whether to institute a system of planning, but instead *how* planning is conducted and *to what ends*. Under capitalism, planning is carried out via hierarchies of ownership and command that ultimately serve a distinctly capitalist "social logic" manifest in the "law of value." In more conventional terms, we can simply say that plans are attuned to prices and aimed, ultimately, at profitability, whether appraised in the near-term or over the longer course of the firm's maturation and survival.

Communism, then, is not simply the replacement of price with plan and it is certainly not the reduction of the capitalist price system to some sort of unadulterated "labor value" or "use-value" in the underlying commodity. Communism is the *annihilation* of "value" and thereby the annihilation of price. Revolutions potentially initiate the process of communist construction insofar as they proceed through "communist measures" that: a) seek immediate decommodification through the destruction of money, prices (including barter, which is a sort of undead price system), and the entire complex of markets and private ownership; and, b) begin to experiment with deliberative systems of planning, allocation, and technical reconfiguration as a means of dismantling social domination. These initial experiments will be iterative and makeshift, taking many shapes and constantly changing. But they

ply require such absurdly high amounts of labor time that there would be no more time left in the day to do anything but produce stuff, since everything would need to be made from scratch. To reduce the amount of labor time required to produce each good requires using outputs from fixed processes, but building up the huge variety of machines and tooling necessary to mass-manufacture every good that might be needed in a single geographically delimited “commune” would take an enormous amount of time while also being absurdly ecologically destructive. Communist society would therefore require both fixed and flexible forms of production, since only the two working in unity can ensure freedom from the need to spend all of one’s time laboring to simply survive or have access to basic material comforts.

Planned and Planetary Limits

Mass production of manufactured goods within a communist society would seem to imply the necessity of a prescriptive form of planning capable of replacing the basic information about public demand for goods that, under capitalism, is held hostage within a system of prices.²⁸ Economists present these prices as if they are merely information systems that allocate goods based on demand. In its extreme, the fever dream of liberalism even imagines that prices are essentially something like a natural law, transmuting thermodynamic information into a form more easily understood by the human brain. In reality, however, prices are mechanisms of social domination. They quite clearly induce an artificial scarcity—visible in the fact that, despite producing more than enough food for everyone in the world, widespread malnourishment and starva-

²⁸ In fact, it is a bit more complicated than this: the system of prices is itself merely the surface appearance of the total social value—a more amorphous and inherently social category, not entirely reducible to its approximate empirical measures.

would not be reducible to their mechanisms. Wherever possible, these deliberative systems might defer to the only true form of democracy: democracy by lot. But deliberation should ultimately take whatever form best serves the character and function of a particular association. Communism is therefore not defined by a particular deliberative mechanism—in other words, communism is *not* democracy—but rather by the penetration of conscious deliberation into all facets of the social metabolism.

Many of the “associations of producers” tasked with manufacturing and distributing goods would likely trace their genealogies back to industrial unions, government ministries, scientific and professional associations, university laboratories, makeshift revolutionary alliances, and of course the capitalist firms that once controlled the entirety of the supply chain. But this would only be a distant ancestry, each offering a few genetic features to institutions evolved anew in the course of revolutionary struggle and communist construction. It is difficult to predict exactly what this restructuring might look like, but a few trends are likely: First, the chains of authority that existed within these earlier institutions would be subjected to reforms designed to reorient capacities toward revolutionary purposes and to eliminate domination within the institution. This would involve the intentional construction, through experiment, of deliberative mechanisms adequate to the function of the association. Because of their technical nature, these associations are unlikely to ever become majority-rule democracies, but we might see a combination of knowledge-graded consensus similar to that used in the management of advanced scientific labs today, and a similarly graded democracy by lot, where any authoritative or representative positions deemed necessary would be filled by random selection from the qualified pool of members—with these “qualifications” determined through deliberative means by some larger body (or the entirety) of the association. Despite the fact that these will not

be simple majority-rule democracies, for lack of a better word we can call this first trend “democratization.”

Second, there would be a tendency toward “agglomeration.” This would not, however, be a uniform process toward ever-greater centralization at the organizational level. Instead, agglomeration would be attuned to the technical and social requirements of a given line of production. In its most minimal definition, we can just think of agglomeration as the tendency to centralize information about a certain field of production within a single, universally accessible platform, something like an industrial Wikipedia, to reduce unnecessary functional redundancies, and, where useful, to issue and oversee certain basic standards or best practices. But in many cases, as we explain below, more direct organizational and geographic centralization would make sense, in which case this tendency toward agglomeration would be more literal.

Third would be the tendency toward “integration.” This would see old occupational and institutional divides broken down, integrating previously segregated spheres of activity such that associations can serve new and broader social purposes. Again, the exact course of integration is impossible to forecast. The precise organizational structure is also difficult to sketch out, since integration would likely involve both the direct subsumption of new tasks within a given association as well as varieties of consultation, confederation, or partial overlap of functionally distinct associations. But one obvious example would be the combination of ecological and industrial institutions: the production of any given good would, from the very beginning, have to trace out its metabolic impact. And we can imagine a similar process integrating agriculture and public health, education and industry, and of course the more general divide between the productive and reproductive spheres.

Envisioning at least some rudimentary characteristics that these “industrial” (for lack of a better word) associations might take on is crucial because, unlike Mau, we do not think communist production will be a largely localized state of affairs that

By contrast, fixed production processes rely on specialized tooling capable of producing a very limited variety of goods (or even just one) but can, as a result, produce large quantities of goods with comparatively little labor time per part. Sensible usage of fixed machinery would see it utilized in a smaller number of locales with the larger output being distributed broadly to places that have less local capacity to perform that given fixed process. Such an arrangement requires centralized forms of administration and planning of productive affairs. The exact geographic distribution and intensity of these industries would depend on various physical characteristics: the weight of its inputs and its finished products (and therefore the energy intensity of transport), the spatial concentration of necessary natural resources (such as ore veins or mineral brines), the volume and form of unavoidable waste that must be sequestered or vented (including things like noise and light pollution), and the potential benefits offered by any economies of scale in terms of energy and material consumption or final distribution of the finished product. Similarly, since a large-scale fixed manufacturing facility would both require and produce a certain number of individuals with sector-specific expertise, basic questions of population distribution and the geographic equity of technical knowledge would also have to be taken into account.

What is typically not visible to the final consumer of commodities today is the extent to which flexible and fixed production processes are inextricably vital to each other’s functioning. In “factory cities,” such as those in China and Vietnam, the two often literally take place within the same complex. More generally, the specialized tooling for any given fixed process is fabricated on a flexible production line capable of churning out tooling of many different designs. Meanwhile, the inputs to that flexible process in the form of materials, fuel/energy, and generic tooling are themselves fabricated in high volumes using a fixed production process. The serpent eats its tail. Localized industrial autarky becomes impossible. Producing absolutely everything using flexible processes would sim-

in a specialized facility exemplifying low-mix processes. In reality, the large factory complexes operated by major industrial conglomerates today have multiple manufacturing lines operating under a single roof, some of which may be more specialized than others. For simplicity, however, we will treat the two separately, referring to high mix low volume production processes as “flexible” and low mix high volume processes as “fixed.”

While it is clear that social imperatives warp the technical process of production toward their ends, the inverse is also true. The laws of nature and the physical characteristics of particular materials set the basic boundaries within which social forces are free to mold production. The decision about whether to manufacture a given item using a fixed manufacturing process or a flexible one is therefore not solely social. Flexible and fixed production styles each have technical advantages and technical drawbacks, alongside social ones. Neither is inherently more communist than the other. Among the most critical features distinguishing the two are the geographic implications of each type of production. Flexible production processes, as the name suggests, allow for operators to easily produce parts of many different designs without needing much upfront labor to reconfigure the machines between each run of different parts. Operators of a given flexible process can fabricate goods to satisfy a great diversity of needs at the expense of being limited to lower levels of output in a given unit of time. This tradeoff is technical in nature and will continue to be true barring any science fiction type breakthroughs (i.e., some sort of universal molecular printer). The design of tooling carries a fundamental antagonism between widespread utility vs specialized utility. Flexible processes would thus be well-suited to handling localized needs with localities all having their own capacity to perform that particular process. The redundancy of different locales having functionally interchangeable machinery creates robust autonomy and productive decision-making power at a local decentralized level.

occasionally features non-local cooperation. It will have to be capable of a conscious and deliberate management of the entire human metabolism with the non-human world. It will thus be inextricably global and fundamentally scientific, even when its instantiations may seem self-contained or appear to be “reversions” to a pastoral life of artisanal production cradled in the blooming of new autochthonous cultures or in the revival of languages and local lifeways freed from centuries of colonization. This means that many foundational associations will be explicitly planetary in nature and even “local” associations will have an implicitly global dimension insofar as they rely on these foundational associations.

In most cases, this global agglomeration will remain loose, with information and affiliation centralized but decision-making widely dispersed. But, in some cases, there will necessarily exist associations that are planetary in every sense. We can imagine, for example, an “atmospheric league” made up of associations of climate scientists, associations of producers in geoengineering industries attempting to draw down remnant atmospheric CO₂ from the capitalist era and balancing emissions from communist production (e.g. via various forms of carbon capture, possibly including direct-air-capture technologies that are not currently viable or scalable), representatives from scientific and silvicultural associations overseeing certain related ecological systems (such as rehabilitating the tundra or other carbons sinks), representatives from various industries in which emissions are an unavoidable necessity (maybe the petroleum used in medical-grade plastics or for certain epoxies used in advanced composites), and various subsidiary associations tasked with things like public education and the training of future climatologists.

Similarly, there would be certain special associations tasked with maintaining the basic substrate of the social system itself—in other words, ensuring against the re-emergence of domination. Many of these would need to have a planetary scope, even if much of their activity is local. These associations would likely evolve

from the uniquely revolutionary institutions that had overseen the destruction of capitalist social domination and guarded against its resurgence in the immediate post-revolutionary period. Though they would have since shed most of the undesirable features once necessitated by open conflict with the capitalist world, these institutions would nonetheless remain the closest thing to a disciplinary, judicial, or military body within communist society. They would overlap somewhat with the more conventional duties of local associations functioning as social arbiters but would not simply be the same form of arbitration carried out at larger scales.²¹

We can also imagine special associations that keep track of or even prohibit the production of particularly dangerous materials (nuclear weapons being the obvious example), that monitor for and mobilize against doomsday scenarios (errant meteorites, deadly pandemics, etc.), or that are capable of enforcing prohibitions against activities that have extremely destructive consequences (for example, polluting a waterway, overhunting, burning coal)

²¹ Though there would be nothing like a law-making authority, a police force, or a standing army, there would obviously be the need for associations that specialize in adjudicating functional conflicts between associations (for example, when an association specializing in historical preservation clashes with one attempting to demolish dilapidated buildings in order to construct new urban infrastructure) or between individuals and associations (for example, someone not being allowed into an association or being kicked out of it attempting to appeal the decision). Deliberative social arbitration would not be an incidental affair but instead foundational—the basic element in which voluntary association would function. We can even think of it as a sort of reflexive “deliberation on deliberation” necessary to maintain the field in which functional deliberation can take place. The exact methods used would be extremely diverse, attuned to specific functions and places. But this also implies the need for larger systems of checks-and-balances to ensure that local arbiters do not devolve into customary authorities that systematically privilege some associations or certain social factions in a locality against others. Thus, a diverse, deliberative form of social arbitration would replace many functions of what we today think of as a “legal system,” requiring a similar degree of complexity and a similar nesting of veto powers.

imperatives often seem to take on a sort of malicious agency in our lives. Bordiga describes industrial fixed capital as “the enemy Monster that hangs over the mass of producers,” monopolizing the collective knowledge of the human species such that “this Monster is killing science itself, misgoverning it, criminally exploiting its fruits, squandering the heritage of future generations.”²⁶ Even if scientific knowledge is key to the future of communism, then, the forces of production are not a neutral algorithmic apparatus that can be simply seized and run for better ends—they are the literal embodiment of the Monster that stands against us.

Thus, any inquiry into what productive knowledge might look like when this monstrous monopoly is ended must first begin with a suitable description of contemporary production itself: its social composition, necessary material inputs, the character of the labor performed and, most importantly, which aspects are most amenable to social reconfiguration versus those that must be annihilated in the course of constructing a planetary industrial ecosystem capable of supporting a communist society. Production processes today can be roughly grouped into two categories: high mix low volume and low mix high volume.²⁷ “Mix” means how diverse the different goods/materials are that are created or processed. “Volume” simply means the quantity of units processed. What exactly constitutes “high” or “low” for volume depends on the type of goods and what sort of machinery is needed to produce them. High mix processes tend to involve machinery designed for dynamic reconfiguration, whereas low mix processes use machines locked into specific configurations with fixed architecture tooling of some kind. A machine shop producing a variety of milled and turned steel parts would be an example of a high mix process, while the steel itself is produced

²⁶ *ibid*

²⁷ See: Nick Chavez, “Technical Expertise and Communist Production”, *The Brooklyn Rail*, December 2022-January 2023.

by associations of various types. For example, local bird watching groups could feed ornithological information into databases managed by regional ecological associations while also overseeing educational and caretaking trips for youth from a given area's communal creche. In this way, even those tasks deemed socially "necessary" would not simply be dull matters of "work," but living rituals pregnant with the upwelling passion of human existence.

The Ecosystem of Industry

Ultimately, however, the blooming multitude of free association is predicated on the freeing of time. And the freeing of time is only made possible through the conscious management of the material world via deliberative planning of the human metabolism with nature. This, in turn, requires an industrial-ecological system capable of mass production. As Bordiga says, once the labor time necessary for basic societal reproduction is reduced to a minimum and scientific knowledge is no longer squandered, then "industry will behave *like the land*, once instruments such as the soil have been liberated from *any form of ownership*."²⁵ Benanav invokes a slightly more whimsical agroecological analogy: "The productive apparatus would have more in common with a 'food forest' than a factory—a garden of edible plants, tended for hundreds of years and designed to provide for a multiplicity of needs, spiritual as much as material."

But, again, it is extremely difficult to predict exactly what even seemingly straightforward activities such as manufacturing a certain good might look like within communist society because the current technical methods for producing any given artifact are inextricably bound to standards of "efficiency" (of profit, labor discipline, etc.) that express distinctly capitalist imperatives. These

²⁵ "The Revolutionary Programme of Communist Society", in Basso 2020, p.458

or that reinstitute social domination and undercut the basis of voluntary association (for example, making subsistence dependent on some new form of money, excluding foreigners from living in an area that is ecologically and industrially capable of sustaining a larger population, reinventing private dominion over socially necessary productive infrastructure, resurrecting gendered forms of power and prejudice, enslaving people, etc.) regardless of whether these activities were democratically decided by an individual association or even an entire locality. Deliberating on and delimiting the nature and extent of these special associations' exceptional powers would be a necessarily global effort, foundational and ongoing—the closest thing to formulating a minimal sort of "constitution" agreed upon by the species as a whole.

Mau argues that "communism is freedom." While not incorrect, we would counter that communism is more specifically *free time*.²² With the labor time savings catalyzed by fixed-purpose machinery, the necessity of labor shrinks as a whole and condenses around the tasks that are the most critical to the reproduction of communist society as such. Even if we include all the services needed to maintain day-to-day life in each locality and account for the reduced contributions from children, the elderly, the ill, those with certain disabilities, or those intractable few who absolutely refuse to work as a sort of personal or artistic statement, this should be no more than a few hours a week per individual.²³ The rest of people's time can be spent freely associating with each other. There

²² "Communism is free time, and nothing else!" is a phrase popularized by everyone's favorite curmudgeonly communist polemicist Jehu.

²³ Ultimately, though, even time spent on this "essential" work should not be so strictly opposed to "free" time. This is especially true when we consider that traditionally non-waged reproductive activities would be acknowledged for their social necessity—thus elderly people taking care of children in the local creche would be seen as contributing to this necessary labor. Similarly, the entire concept of disability would be transformed by the destruction of the separation between people and guarantees of subsistence. The use of "necessary" here is not intended as an ontological opposition to "free," but instead as a practical description.

would be no more need for odiously long working hours and no impulse to reduce the quality or safety of working conditions for the sake of profit disguised as “efficiency.” People will choose to perform a given productive process either because they are enthusiastic about the process or their desire for the output of that process is high enough to justify the labor. Processes that nobody wants to do are simply not done. If this annoys anyone, they are free to find the other people annoyed by it and form an association for this purpose. If there are particularly odious or unpopular activities that are nonetheless essential, the amount of work that needs to be done is made as quick and painless as possible. We can imagine special associations formed for the purpose of streamlining these processes and recruiting particularly altruistic individuals to commit a few hours to such tasks. At the most basic material level, it is the outputs from certain critical production processes that will enable the freedom to associate and produce a variety of goods. The expansion of free time and creative experimentation enables communards to further revolutionize the productive ecosystem generating these outputs, which serves as the basic material substrate within which communist society flourishes. The causes and effects of free time are thereby locked in a mutually reinforcing feedback loop, building from and strengthening one another.

Though the various “special” associations devoted to “necessary” tasks may be particularly important, most associations would be entirely conventional, relatively small in their membership, and would have little to do with the mass manufacturing of goods. The exact functions of such associations would be so diverse as to defy any simple summary. Any group of people could form any type of association for any purpose, within the bounds of certain social and ecological limits set by deliberative means at various scales—and with the presumption that such limits are only set when deemed “necessary” in some sense. Most of these limits would be parochial affairs, such as prohibiting especially destructive uses of local resources, with these proscriptions set by the associations that tend

to those resources or the residents who would be affected by their destruction. It is in this sense that general-purpose geographic associations (Mau’s “communes”) might be formed, as primarily prescriptive agencies determining the limits deemed desirable by locals impacted by certain uses of space and resources.²⁴

There is nonetheless a basic tension between the relatively narrow need to “optimize” production to free up time and the much broader qualitative needs both enabled by this freeing of time and structuring it, in the sense that industrial production itself would be reconfigured to serve entirely new qualitative purposes for those participating in it (rather than being a begrudging necessity in which a certain quantity of goods simply must be produced to meet a socially-mandated quota). In other words, production is not just an algorithm into which demands can be input and products generated. As Benanav argues: “no matter how powerful the planning algorithm, there will remain an irreducibly political dimension to planning decisions—for which the algorithm’s calculations, no matter how clever, can only serve as a poor substitute.” This is the basic function of deliberation and the reason why it must span society from top to bottom. And, in fact, most associations would have little to do with production. Many would simply be institutions for different forms of art and enjoyment—sports associations, theater troupes, culinary groups—and, at the more general level, the breaking down of archaic divides between spheres of life would see educational, reproductive, and scientific endeavors integrated into a number of otherwise leisurely, playful, and passionate pursuits organized

²⁴ Even here, however, the difficulty of conflicting interests is apparent, since it makes little sense to give localities absolute veto power over activities taking place “in their backyard” if these activities have already been decided upon by the larger-scale associations that intercut these localities. Again, various forms of social arbitration necessarily exceeding the local scale would be central to the process, and different areas would likely settle on very different balances between the effective powers of social units of different scale.