

# How To Squat In Chicago

CHA specific guide

Unknown Occupants



janurary 1st 2023

# Contents

<b>THINGS TO KNOW BEFORE YOU ATTEMPT TO SQUAT A BUILDING . . . .</b>	<b>3</b>
<b>HOW IT HAS BEEN DONE IN CHICAGO . . . . .</b>	<b>3</b>
<b>CHA SQUATTING AS DIRECT ACTION . . . . .</b>	<b>4</b>
<b>SCOUTING . . . . .</b>	<b>4</b>
<b>CRACKING . . . . .</b>	<b>5</b>
<b>ESTABLISHING RESIDENCY . . . . .</b>	<b>6</b>
<b>SETTING UP YOUR SQUAT . . . . .</b>	<b>8</b>
<b>WATER: . . . . .</b>	<b>8</b>
<b>GAS: . . . . .</b>	<b>8</b>
<b>ELECTRIC: . . . . .</b>	<b>8</b>
<b>REPAIRS AND STUFF: . . . . .</b>	<b>9</b>
<b>COURT AND LEGAL PROCEEDINGS . . . . .</b>	<b>10</b>
<b>EVICTON DEFENSE . . . . .</b>	<b>10</b>
<b>LIVE LIBERATED . . . . .</b>	<b>13</b>
<b>APPENDIX I: USEFUL TOOLS FOR SETTING UP YOUR SQUAT . . . . .</b>	<b>13</b>
<b>APPENDIX II: FURTHER READING . . . . .</b>	<b>13</b>

## **THINGS TO KNOW BEFORE YOU ATTEMPT TO SQUAT A BUILDING**

Squatting is hard! It's easier with other people. Scouting, working on the property, moving in, interacting with management and police, maintaining the squat, and going through the court process are all easier with a crew. Forming a crew involves building trust and getting on the same page, especially about the fact that...

Squatting can be risky. Opening a house (or "cracking") carries the risk of burglary charges, especially if you're caught with tools. Even after you're in and changed the locks, there's still a possibility of being charged with trespassing. Further on, we will describe some strategies to convince police you are not a criminal trespasser but a resident with the right to a civil eviction trial (a process called "establishing residency"). Everyone in your crew should be aware of the specific legal risks involved, and we think it's a bad idea to try to convince people to squat who don't understand that squatting is illegal or do not feel okay about interacting with police.

Squatting does not often result in a permanent place to live. Eviction attempts by the Cook County Sheriff (after a hopefully lengthy court process) are inevitable. Violent illegal lockouts (sometimes referred to as "constructive evictions") have also been attempted with sledgehammers and violent threats by management companies and private security, sometimes with CPD watching on. Having a network of connections with other squatters, neighbors, and/or homies will help immensely with eviction defense or emergency housing support if or when those are needed.

## **HOW IT HAS BEEN DONE IN CHICAGO**

There are a few different types of squats that are possible in Chicago with varying degrees of legal protection and flexibility:

1. Living on unused or public land (sleeping on streets, pitching tents, building structures, etc); almost no legal protection but easy to pull off for somewhat long periods of time and very common.

2. Living in abandoned privately-owned buildings; limited legal options and often short-term, but common.

- 2.5. Living in abandoned privately-owned buildings and eventually paying the back-taxes; more legal protections and can result in "permanent" accommodation, but can be expensive and is more difficult and less common in Chicago than other cities.

3. Living in foreclosed (often called "bank-owned") houses and establishing residency; very favorable legal options in Chicago (mostly a result of the ability to negotiate large sums of relocation assistance in the court process), and common in the 2010s but it has gotten much more difficult to find viable houses. See the original "How to Squat Chicago" zine for more info!

4. Living in abandoned units of Chicago Housing Authority buildings and establishing residency

This zine will focus on the last type, squatting so-called public housing. We do not exactly know what the legal protections are, but it seems to generally last a decent amount of time because it leads to a civil court process like bank-owned squat (but most likely without the big

payouts). One of the biggest benefits over bank-owned squats is the incredibly large amount of vacant CHA units and the ease of finding them.

## **CHA SQUATTING AS DIRECT ACTION**

Squatting CHA properties is direct action against the city's public unhousing strategy. CHA contracts out private, for-profit management companies who force out tenants, letting buildings sit empty and decay, just so the city can deem them uninhabitable and prepare the buildings or lots to be sold (this last part of the process is called "scheduling a building for dispossession or demolition"). In some cases, the people who own or run the management companies also own or run the development companies or construction firms that buy the dispossessed or demolished houses. Sometimes the management companies ARE the development companies.

This process is especially pronounced in "gentrifying" neighborhoods, those seeing rents increased, people displaced, and houses renovated or built. Very very often, white people and businesses eventually move into neighborhoods once home to black and brown communities. We believe that squatting CHA properties is anti-gentrification direct action. But it's still important to be intentional and thoughtful about what you're doing and why you're doing it, especially because squatting and gentrification have an entwined history in so-called America. In the 1960s and 1970s, the federal government actively and intentionally gentrified specific neighborhoods of cities across the country through "urban homesteading" which allowed people, often those with lots of money and time, to move into abandoned buildings and gave them the deed when they brought the building up to code.

## **SCOUTING**

Finding a potential building to squat is called scouting. The first step to scouting a CHA unit can be deciding which neighborhood(s) to check out. There are CHA units in every neighborhood, and so there are at some point or another going to be empty CHA units in every neighborhood. But as we mentioned earlier, a lot of the empty units, especially those scheduled for dispossession or demolition, are in actively gentrifying neighborhoods.

Go for a walk, bike, skate or drive and see what you can find. Lots of CHA properties have a very specific look to them, which can vary neighborhood to neighborhood, but once you recognize them, you'll see them everywhere. All seem to have signs that say "No Trespassing, No Loitering, No Soliciting" and a plaque with the name of the management. Some of the current contracted management companies are Manage Chicago, Hispanic Housing Development Corporation, and East Lake.

A lot of information on CHA housing can be found through a few internet searches. The CHA website shows which company has the contract for a specific neighborhood. CHA divides the contracts into what they call "Scattered Site Regions" and the contracts change frequently. Specific research into public data could even reveal specific addresses of buildings scheduled for demolition or dispossession. But scouting can be done without any of this online research.

Some signs that a house is empty are plywood boards over windows, lots of old mail, out-of-season holiday decorations, and no trash in the bins. CHA contractors often do general exterior

upkeep and landscaping for empty units, and sometimes they leave grills or children's toys outside.

When you identify a potential empty unit, you can check by knocking on the door. If someone answers, you can pose as a neighbor or canvasser if you bring a clipboard. If no one answers, it could be empty. You can try at different times to be really sure. Another classic squatting technique is "taping doors": putting a piece of tape on the bottom part of the main doors and checking back to see if the tape is attached after a day or two. Make sure to pay attention to the weather though, because rain can untape a door.

Once you found the spot, it's helpful to prepare for cracking by looking for cameras and trying to identify potential ways to get in. Check windows and doors. Some of the sickest squats around have just been open.

## CRACKING

Opening a building to squat it is called cracking. This is usually the most risky part of the process. You can do this at night wearing masks and clothes that conceal your identity. You could also do this during the day, wearing a safety vest or other clothes that make you look like a construction worker. The biggest risk at night is being seen or heard, so watch for cameras and be sneaky. Daytime cracking might be a better option if the unit is in a building with other occupants and you are going to use power tools. Daytime cracking is potentially risky if the people cracking are also the people who are going to live there.

CHA units almost always have deadbolts. When CHA contracted workers are trying to get into a unit (either to try illegal lockouts of a squat or just when they otherwise don't have keys to non-squatted units), they drill the locks. This is an effective strategy for the daytime, but difficult. Aim for slightly above the keyhole with a driver or step-bit, but also be prepared to drill for hours and fuck around in there.

Usually windows have pretty small plastic "locks" that sometimes can be cut with a handsaw. Windows can also be broken, usually a last resort because then your squat has a broken window. If a window is boarded up there might already be a broken window underneath. Frequently, these boards have star-bit screws, not standard Phillips-head.

Some CHA units have security closets that are left unlocked. From there, you have a good amount of privacy to cut through the walls to get in. A lot of houses only have drywall and insulation, which you can get through with hand tools. Sometimes there are plywood boards, which usually require a powered saw.

Be creative and confident. Try to be prepared with appropriate tools, but also remember tools can be used to prove intent or even carry an additional charge if you're arrested. If the cops do show up, you can run, hide, or try to talk your way out of it. Unless it's the middle of the night or you've been seen breaking a window, confidently telling the pigs that your dick supervisor Jim from the management company has you working late again might just be your best bet.

After you're in, check out the place. See if utilities are on, see if there's a furnace and hot water heater, and look around for mold or other damage. All of this can be dealt with later, but if things are really fucked it might not be the spot. You might want to leave a door or window unlocked so you can come back later and change the locks. Or just do it right then.

Changing the locks can be done with minimal tools and a deadbolt set that you can get at most hardware stores. If there are multiple doors, gates, entrances to the unit it's good to have control over a lock on each of them.

## **ESTABLISHING RESIDENCY**

Next you want to get the place ready, both for establishing residency and for living there. After opening a spot, the management and police might come as soon as the next weekday, so be prepared to establish residency as soon as possible. This might mean planning when you crack around weekends, or even holidays. If the spot needs a lot of work, you can try to put off the residency interaction by being sneaky and limiting use of doors to nighttime. Once you open the doors in the daytime, try to have someone home at all times during weekday business hours to hold down the place until management and police show up.

When establishing residency, you can attempt to stay inside if you have street-level windows. However, if the police think you're a trespasser they can come inside so it's a good idea to try to make the place look like someone lives there. This can include having furniture set up, putting posters on the walls, covering any holes in the walls, and sweeping the drywall or trash off the floor. Setting up utilities, especially electricity can also be helpful if the cops come inside.

Certain documents are used when establishing residency. These can include a "lease" back-dated a week or two, a government-issued ID, mail to your address, and utility bills. The most effective has been having a lease and a government-issued ID with a matching name (or even a matching address if you have time to get some mail and go to a Secretary of State's office). However, the decision is up to the discretion of the sergeant.

Here's an example of what the residency interaction can look like:

1. Management, security, and/or the CHA notice a building that is supposed to be empty isn't empty and show up. Sometimes they just knock and act pretty normal, sometimes they yell stuff at you about trespassing, sometimes they just start drilling your locks and try to force you out. It depends. Eventually, they might call the police. Or they might leave and be content to just start the civil eviction process.

2. Police show up. If management is trying to drill the doors and force you out, you could even call them yourself, but this is of course risky. Usually it's first the beat officers ("blue-shirts") that arrive. They cannot usually determine you to be a resident; usually a sergeant or lieutenant (a "white-shirt") has to make that decision.

3. Police talk to management, who will tell them you are squatters. Then the police might talk to you. When talking to the police, it has been effective to ask to speak to the sergeant and to emphasize that you are a resident, you live in this house, and that this is a civil matter. They might ask you for certain documents, or if it seems like they think you are a trespasser, it might be helpful to offer it to them. It can be very helpful to know information that's on your "lease" if that is something you're showing them, including the date it started and who you signed it with.

There are many variations of this that can happen. Role-playing and practicing this interaction have helped us a lot in preparing for the different choices management and cops can make. After establishing residency, you are generally good to start living in the squat openly but it is possible that management or the cops will show up again and you'll have to have this interaction again.

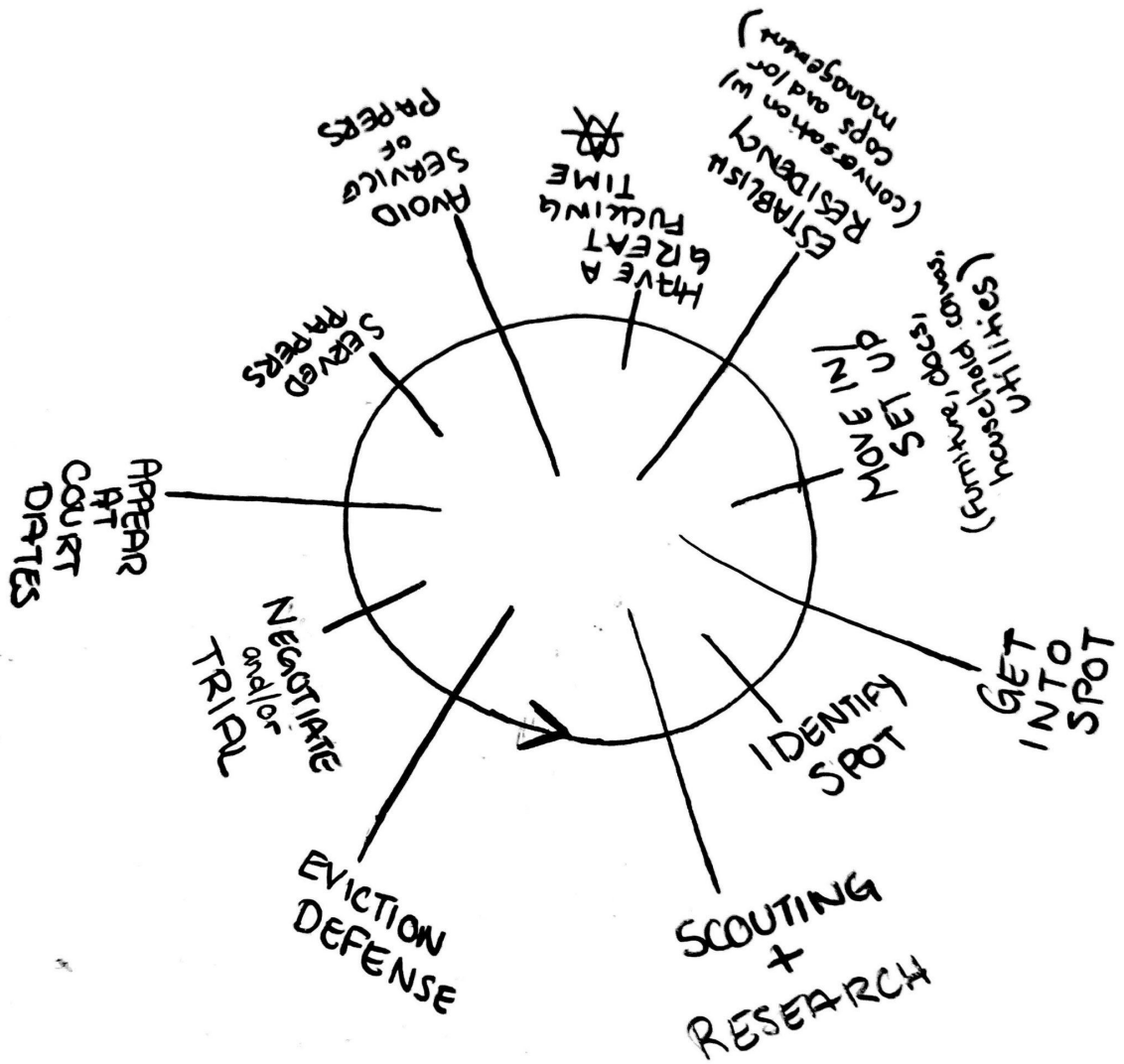

## SETTING UP YOUR SQUAT

Now that you know the management company is going to start a civil eviction process you can start doing a lot more in and around the squat. This could look like having all your friends over to work and clean, have a big meal together, party all night, or maybe you just wanna lay the fuck down. Really whatever you want. The place is yours, you get to decide what it's gonna be like and what your gonna do next.

Getting heat, electric, and a system for drinking and flushing water all set up early on can make your life easier. It's not necessary to have them all working so y'all can talk about which feel the most urgent.

### **WATER:**

You can usually turn the water on yourself. Start by locating the inside main usually found in or near the utility closet. There will likely be a red (hot) and a blue (cold) wheel handle that you need to turn on. If the water is cut off to the house (inside main) from the main city line, the city valves are usually pretty easy to find in front of the house between the sidewalk and the street, under a heavy cement access panel that you can pry up with a flathead screwdriver or crowbar.

If you turn on the water and have leaks, you have a few options. You can cut out the wall where you see signs of a leak, repair the pipe, and turn the water back on (turn it on a LITTLE BIT and wait - seems obvious but we learned this the hard way) to see if you fixed the leak and if there's another leak further along the pipe. It is helpful to have at least 2 people when doing this; 1 person at the valve and 1 person at each leak. Some units, especially those without mold inside the walls, have just a few leaks near faucets and showers. But in a big moldy building that's been uninhabited for years you could end up chasing leaks throughout the whole plumbing system.

Instead of trying to fix the whole plumbing system, you could cut the pipe near where the water main enters the building, and install a spigot. This still requires some tools, materials, and plumbing knowledge, but will mean less mopping, fewer holes in the walls, and water access sooner. You will have to haul water from the spigot for flushing, cooking, drinking and cleaning. Flushing toilets is usually the largest use of water in a house; consider flushing with greywater from the sink. Five-gallon buckets are easily available and can be used to flush toilets by quickly pouring a few gallons of water directly in the bowl. Water cubes and jugs can be used for water to drink and clean dishes.

You could also completely forgo running water in your squat and haul from a public spigot. Hardcore!

### **GAS:**

Call Peoples' Gas and set up an account at your new address. Nice!  
Gas meters are usually just on the side of the house somewhere.

### **ELECTRIC:**

Call Comed and set up your account at your new address. Usually this will get your electricity on within minutes. If you don't want to or can't afford the bill or it's something weird like the meter is in your neighbor's basement and they hate you or whatever it is, here are some ideas:



- hella battery packs, charge at library or friends' places
- run extension cord from wherever you can
- car battery with inverter
- figure out how to wire directly from city poles
- if you have running water, rig up something with a water-powered generator \* if anyone does this or knows someone who has PLZ get in touch that's sick af
- gas generator
- propane stove
- candles, string lights, typewriter, battery powered tape player, etc.

Sometimes, if the meter is locked or there are bigger issues or repairs needed the utility company may tell you to call your landlord about those things. If you're not sure what repairs need to be done you can tell the utility workers that your landlord is a unresponsive piece of shit and ask if they have advice on getting things set up yourself.

## **REPAIRS AND STUFF:**

Some common issues in CHA houses are plumbing problems, mold, and broken HVAC furnaces.

If you have mild surface mold, cleaning with vinegar and applying anti-mold paint like Kilz can be effective. If you found lots of leaks, there is likely a lot of mold deeper in the walls. You can remove moldy drywall, insulation, and boards with prybars and saws. Masks and gloves are good safety precautions for both mold and insulation. Opening up lots of sections of moldy wall and using mold bomb foggers can be very effective, but can require leaving the house empty for a day or two.

If you don't have a working furnace, electric space heaters are a good heating option. Be careful though, space heaters can easily start electrical fires. Avoid leaving them unattended for long periods of time and plugging them into extension cords! Also have a fire extinguisher! If you don't have electricity, getting big batteries and charging blocks and charging them at the library can be effective. Batter powered LED lanterns, string lights and candles are nice for lighting. If you can't get either gas or electric working, it might not be a good spot for the winter, but there are still options like propane heaters, but make sure to check if they are made for indoor use because of carbon monoxide.

The alleys in your neighborhood are often a good place to find furniture, beds, rugs, and other items you might need either to make it look set-up for establishing residency, or to just have it set-up for y'all to start living there. Moving around the first of the month can make finding these things a lot easier as people tend to fill the alleys with unwanted but totally usable furniture. Free craigslist and other trade/sell sites can be a good resource for finding any appliances you might need, like a stove, fridge, etc.

## **COURT AND LEGAL PROCEEDINGS**

The first part of any legal eviction proceedings will be attempts to serve you eviction papers. In CHA squats, management might put up "Affidavits of Service" on your door. The CHA lawyers have not yet attempted to claim that these documents count as legal service, but they might satisfy some other procedural requirement. Either way, don't freak out if/when you get one; they can even be used to prove to police that you're not a trespasser because you are in civil eviction procedure if they come around and you have to do residency stuff again.

Next, the CHA will hire the Cook County Sheriff to try to serve you an "Eviction Summons" and "Eviction Complaint". The longer you can avoid service the more time you'll have in your squat. They can serve any person they consider an occupant of the house over the age of 13, so make sure anyone coming in and out of your squat is aware of the situation. Checking peep holes or asking who's there before opening doors is very helpful.

If the sheriff can't serve you, the CHA will ask to judge to allow them to hire a "special process server" who you should also avoid the same way. They might look like a lawyer in a suit or just a regular person so, again, be alert when opening doors, entering, and exiting! If they can't serve you either the judge will eventually allow the management/landlord to just serve you by posting the eviction papers on the door.

The sheriff or process server might have already left papers in your mailbox or doorstep, but these technically should not count as service until the judge has approved service by posting. If you have these documents, you could show up to your court dates and follow along this process without identifying yourself. If they try to claim to have service, you could speak up and try to dispute it, but this was more effective when court was in-person.

In court be prepared for things to move fast and to not to be allowed to talk very much. Some judges might be very annoyed with you if you speak when they don't specifically want you to, but you can try to advocate for yourself especially by asking for more time because you work, or because it's cold out, or because you need to find a lawyer.

The court's procedure has changed a lot. At the time of writing, eviction court was still online over Zoom, and continuances have been pretty automatic and based on a timeline that involves referring people representing themselves ("pro se defendants") to the Early Resolution Program (ERP). You can use this program to get a lawyer or try to find a public interest lawyer from a legal aid organization, but you could be dropped if they think you're not being honest about your claim or with your documents.

Generally, you can try to get as many continuances as possible, and then either negotiate a move-out date or go to trial and try to delay things as much as possible in trial. This is all very new, so we aren't really sure what works well and what doesn't.

## **EVICTON DEFENSE**

So let's say you decided against negotiating a move-out date, lost your trial, and now the court issued an eviction order. Technically the sheriff can show up to get you out as soon as 24 hours after the order is filed with them, but usually it takes longer. You should get a letter in the mail before they show up. You can check when they'll show up by checking if the eviction

number from this letter is on the schedule on the sheriff's website. This schedule only shows the next three days so you'll have to check pretty often.

Once your day is here, you have lots of options. You could drop banners and call the press. You could assemble a crew and barricade yourself in your house to hold out as long as possible. You could keep piss buckets (or other stuff) by the windows ready to unleash on an unsuspecting deputy.

They will probably eventually get you out of there. Don't let that stop you from going hard if that's what you want to do! Defending something you built and love with your crew is a beautiful thing and squat eviction defenses have grown into much larger street actions all over the world. We would of course recommend concealing your identity if you're going to go down that road. Also squatting is ultimately about the connections we make and not the houses we live in. There are always more buildings to squat.

# TYPES OF BARRICADES:

"THE FLUSHING"

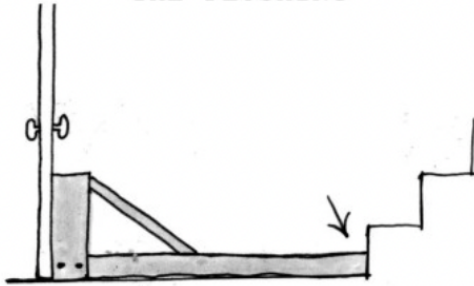

"THE BIRD COOP"

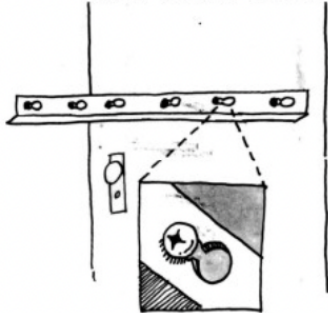

"THE TITANIUM DAN"

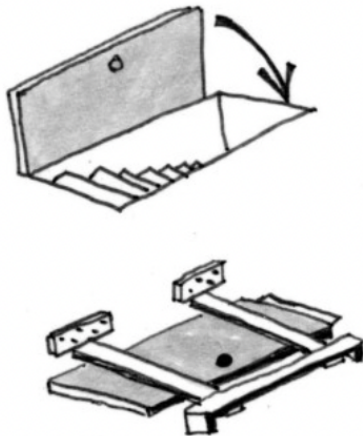

"THE OLD BOY"

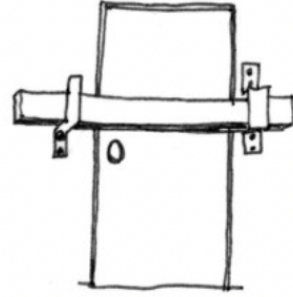

"THE STOMPER"

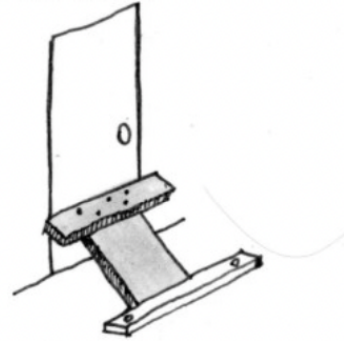

"THE HOT-WING"

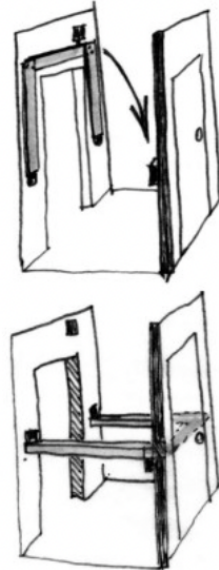

## **LIVE LIBERATED**

Court may not start for a few months, but your squat is ready to go as soon as you are. The amount of things you can do in a squat are innumerable. Over the past year we've hosted teach ins, dance parties, scheming meetings, holiday celebrations, library open hours, mud wrestling tournaments, skill shares, one (1) folk punk show, distros, reading groups, and soo many neighborhood dinners, cookouts, and potlucks. We have learned plumbing, carpentry, and how to live together. It can be a lot to constantly sustain your squat and work together with other people. Make sure you feel supported and can avoid burn out. Let your homies know what your needs, wants, abilities and dreams are. Also, it is super fucking cool to interact and build relationships with your neighbors whether they're squatters or not. A lot of people in Chicago hate the City of Chicago, so you've already got that on your side if you talk to them about what you're doing. And if you are kind and giving to your neighbors it's common for them to respond with the same. We can't wait to hear about and hopefully interact with what you do at your squat. Good luck, have fun, and remember this is just advice based on our experience, don't let us tell you what to do!

## **APPENDIX I: USEFUL TOOLS FOR SETTING UP YOUR SQUAT**

- wireless drill & standard set (CHA favors star bits) & a variety of medium to large drill bits and drivers
- prybars
- screwdrivers
- hammer
- small hacksaw
- spray paint
- ladder
- water key and/or metal detector could be useful for finding the water main in weird situations but we've mostly not needed those

*\*AGAIN, keep in mind legal risks re: intent and certain tools in certain situations...*

## **APPENDIX II: FURTHER READING**

- "How to Squat Chicago: A Rough Guide"  
(Chicago squat zine focused on foreclosure squatting)
- "Survival Without Rent" (old-school NYC squat zine)
- "Squatters Handbook" or "It's Vacant, Take It"

(SF squat zines from Homes Not Jails)

- “Against the Legalization of Occupied Spaces”

(zine from two Milanese squats about squatting and legalization/liberalization, direct action, and self-organization)

- *Nine-Tenths of the Law* by Hannah Dobbz

(book-length history of squatting in so-called America)

The Anarchist Library  
Anti-Copyright



Unknown Occupants  
How To Squat In Chicago  
CHA specific guide  
janurary 1st 2023

**[theanarchistlibrary.org](http://theanarchistlibrary.org)**